

**Also available as type KMS:
Safety contact mat with circuit-closing function !**

The safety contact mat ASK is used for safeguarding sections in hazardous areas around machines, presses, robots and other types of active equipment. Stepping on the mat surface triggers a control signal to the stop circuit of the potentially hazardous motion. This fast contact occurs due to the area switch design on the inside of the mat. A single compound polyurethane material assures impermeability against oils, water and dirt. An anti-slip surface is also implemented into the design. Optional checkered surfaces in aluminum or high-grade steel can be used in areas where high mechanical demand is placed on the upper mat surface. Safety evaluation controls the switching function of the ASO safety contact mats.

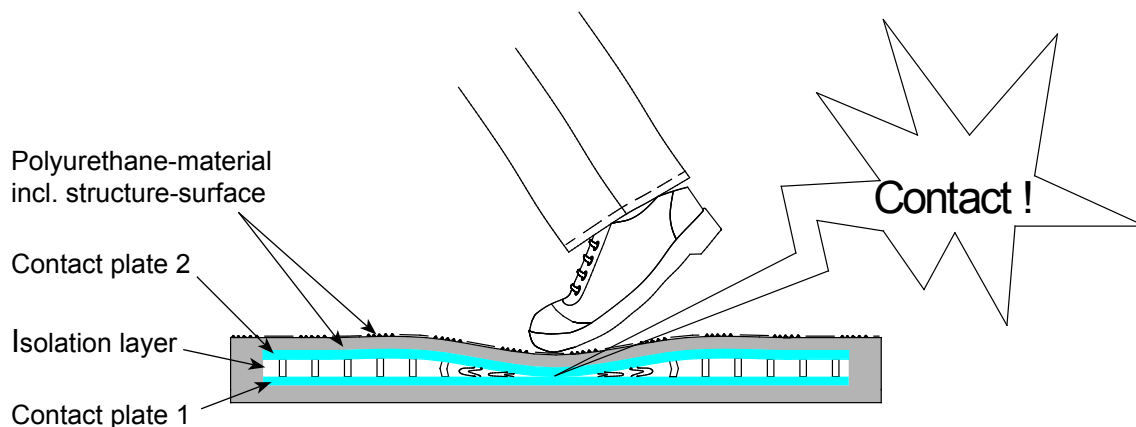

The principle of the safety-contact-mat



The structure

The basic construction of the ASO Safety Contact Mat consist of two conductive plates which are separated by a proprietary isolating layer. These plates are completely potted in a polyurethane material so that they are impervious to oil, water and dirt. The top consists of a slip resistant checkered pattern. This surface provides excellent resistance against oil and grease. Two cable exits are provided. These cables consist of one M8 male plug and one M8 female plug in standard construction (Optional Cable Exits are available upon request). Mounting to the floor can be realized with optional aluminum ramp rails RS 14 or BS 14. A mounting frame can be supplied for flush mounting with the floor.

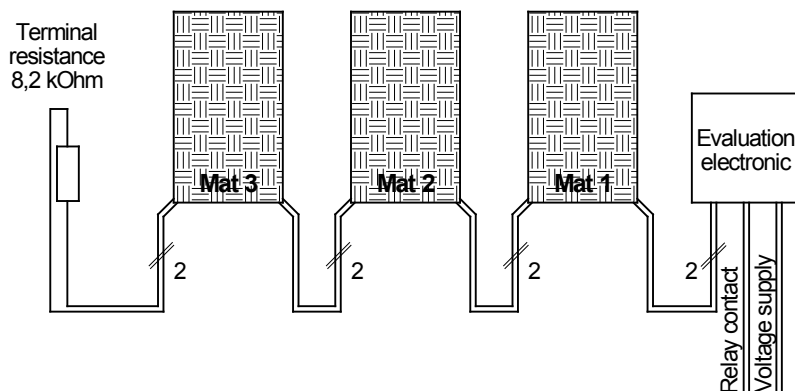

Please pay attention to:

- Up to 10 contact mats wired in series may be connected to one evaluation control unit. The maximum total area can not exceed 10 m²!
- The total cable length can not exceed 75m.
- The 8.2 K Ω terminal resistance must be connected to the last mat in series when several mats are connected !
- Please inquire separately for mats with recesses or special shapes.

Signal processing

The ASK safety contact mat is fitted with 2 two-core connecting cables and offers the possibility of connecting several mats in series up to a maximum total area of 10 m². One end of the cable is connected to the safety evaluation control electronics and the terminal resistance is connected to the other end (prepared at the factory). The Safety Evaluation control electronics provides monitoring for the entire circuit including the cabling route and the mats, by monitoring the terminal resistance. The two surfaces of the mat make contact when stepped on and the resistance is bridged. This immediately causes a signal within the electronics that is then given as a potential free output for the contact-mat by the relay. The entire switching circuit is monitored at the same time for damage to cable or manipulation.

Ramp Rail RS 14

The ramp rail RS 14 provides secure mounting capability for the safety contact mat. The angled design reduces tripping and slipping when mounted to the mat. The integrated channel can be used for clean and safe installation of the connecting cable.

Mounting Rail BS 14

The mounting rail BS 14 can be used to attach the safety contact mat in less accessible areas (for example at machines, shut-off positions, walls, etc.). Also the integrated channel can be used for clean and safe installation of the connecting cable.

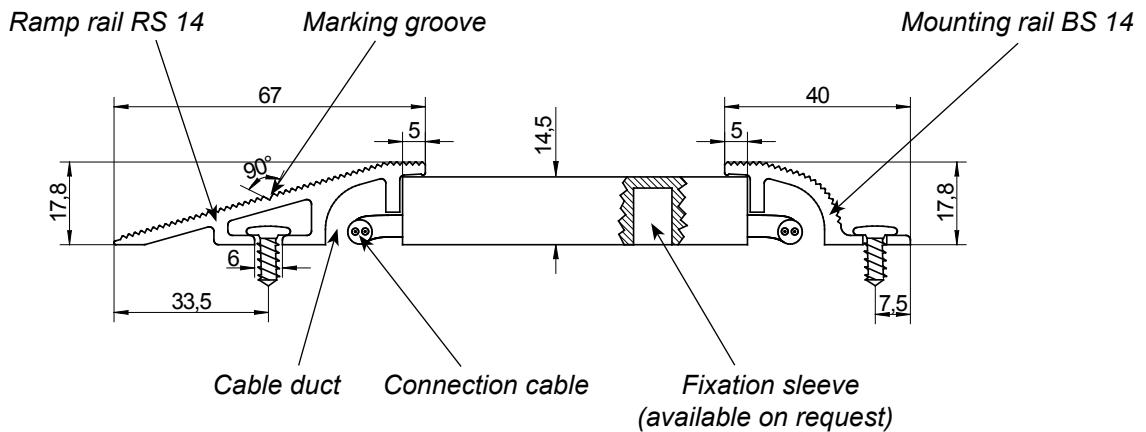

Fixation sleeve

This enables the safety contact mat to be fixed to the floor without additional space being needed.

Covers

Additional protection for the mat surface can be provided from the factory or for do-it-yourself mounting. All coverings can be replaced. Special covers or colors on request.

RF2	- Rubber checkered cover, oil resistant
ARB	- Aluminum checkered sheet
TBV	- Stainless steel plate
RF	- Checkered cover with one compound mat

Type code information

ASK - 1P2 - RF1

Designation

ASO - Safety Contact mat

Number of switching zones within one mat

Base plate type

P - PVC, grey
A - Aluminum
V - Stainless steel
U - One compound mat

Cable version

0 - 1x connection cable 2-wire
1 - 1x connection cable with integrated terminal resistance
2 - 2x connection cable 2-wire
3 - 2x connection cable with resistance shrunk on cable
4.0 - 1x M8 male plug/1x M8 female plug
4.2 - like 4.0 with M8 connect. cable 2,5m
4.3 - like 4.0 with 5m cable M8 fem. plug and M8 resistor male plug
4.4 - like 4.0 with 5m cable M8 male plug and 5m cable M8 female plug
5.0 - 1x integrated resistor and 1x M8 male plug / 5m cable with M8 female plug

Cover quality

RF 2 - Oil resistant
ARB - Aluminum
TBV - Stainless steel
RF - Checkered cover with one compound mat

Special covers or colors on request

Technical specifications for safety contact mats

Max. Dimension:	2500 mm x 1400 mm	
Standard dimensions:	1000 mm x 750 mm	
available from stock	1000 mm x 1000 mm 1000 mm x 1500 mm	
Construction height:	14 mm with covering	
Weight:	approx. 15 kg/m ² (without covering)	
Inactive border:	max. 10 mm on all sides	
Switching pressure:	Round body \varnothing 80 mm = ca. 150 N	
Static load:	max. 2000 N over \varnothing 80 mm *	
Response time:	max. 25 ms *	* Tested according to EN 1760-1
Switching cycles:	min. 1,5 Mio.*	
Material:	Polyurethane black	
Protection class:	IP 65	
Temperature range:	0 °C to + 60 °C	
Chem. resistance:	Oil, greases	- good
	10 % acid	- resistant
	10 % lye	- resistant
Maintenance:	The mat is maintenance free. Functional testing on an annual basis is recommended	
Connection cable:	Standard: Pluggable, 2 x 0,34 PU-cover black with M8 male/female plug, 120mm	

Technical specification Ramp rail RS 14

Material:	Aluminum AlMgSi 0,5
Standard delivery lengths:	2 m / 6m
Weights:	approx. 788 g/lfm

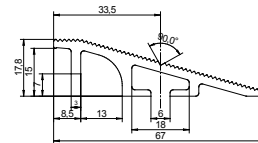

Technical specification Mounting rail BS 14

Material:	Aluminum AlMgSi 0,5
Standard delivery lengths:	2 m / 6m
Weights:	approx. 408 g/lfm

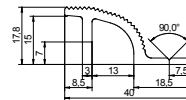

Technical specification corner connector EVA

Material:	PA 6 black
------------------	------------

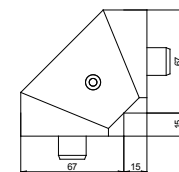

Technical specification cover

Type:	RF2	ARB	TBV
Material	Synth. rubber NBR	Aluminum AlMg 3	Stainless steel
Tape	Checked cover	Checked cover	Tear cover
Color	black		
Material thickness	max. 4,5 mm	max. 4,5 mm	max. 4,5 mm
Delivery widths	1,4 m	max. 1,5 m	max. 1,5 m
Delivery lengths	up to 10 m coiled approx. 3,8 kg/m ²	max. 3,0 m approx. 7,0 kg/m ²	max. 3,0 m approx. 11,6 kg/m ²
Chem. resistance			
Oil	good	good	very good
Gasoline	good	good	very good
Solvent	sufficient	good	very good
Acid diluted	good	good	very good
Leach diluted	good	good	very good

! Assembly Information

- The mounting surface must be absolutely even, clean and dry.
- Mats may not be glued on the bottom.

Lay out and position the mat correctly with the base plate downwards. Mats may not be broken or bent. Safety-Contact-Mats may not be changed in any way. Cut outs or shortening is not possible.

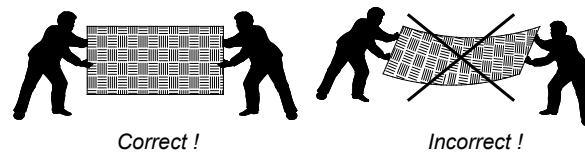

The mats shall be joined end-to-end when laying several mats together. Then connect up the mats electrically and check the electrical resistance. With un-actuated mat, the resistance value must amount to $8,2 \text{ k}\Omega \pm 2\%$.

During cable laying inside the ramp- and/or in the mounting rail pay attention that the cable is not pinched.

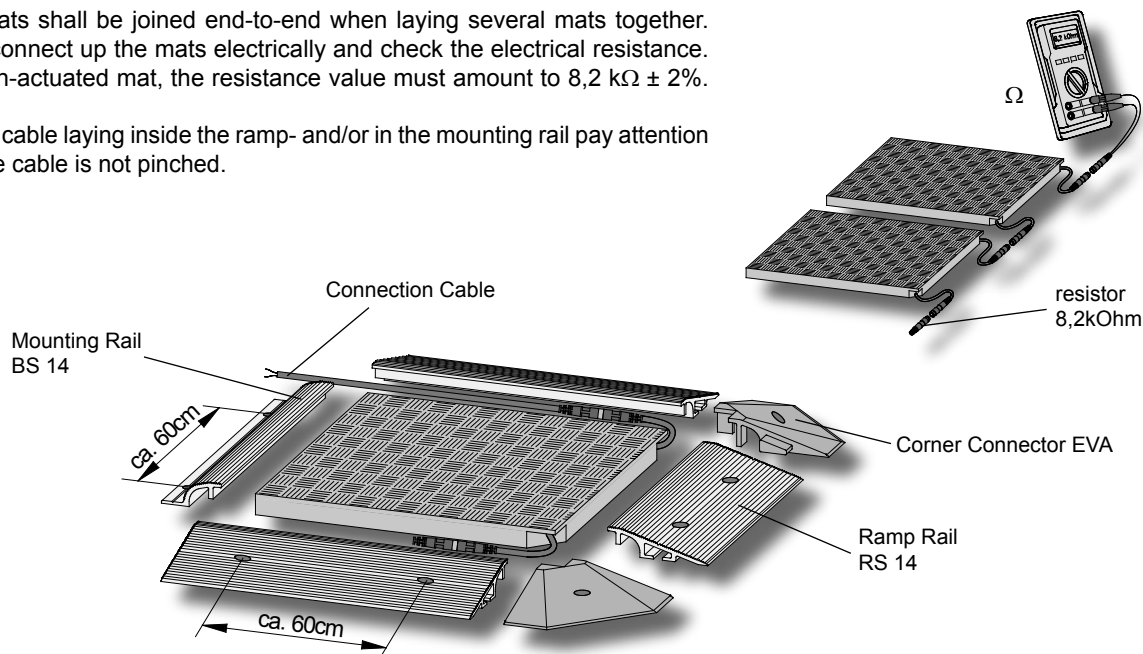

Assembly

When using corner connectors the ramp rail must be shortened around 20mm for each corner connector. The corner connector nearest the cable is to be mounted from above over the cable in such a way that the cable is guided safely in the cable duct (fig. 1). Afterwards drill and fasten it to the bottom with 6 mm dowel and suitable screw. Push the ramp rails laterally to the mat and then on the fixation-pin of the corner connector (fig. 2). Mark the fastening points along the marking groove on the rail and pre-drill 10 mm for the intended plugs. Fasten the rails on the bottom with 6 mm dowels and suitable screws (approx. all 60 cm) and close the openings with the plugs (fig. 3). Push the corner connectors laterally to the mat and then the fixation-pin into the rail (fig. 4). Afterwards drill and fasten it to the bottom with 6 mm dowel and suitable screw.

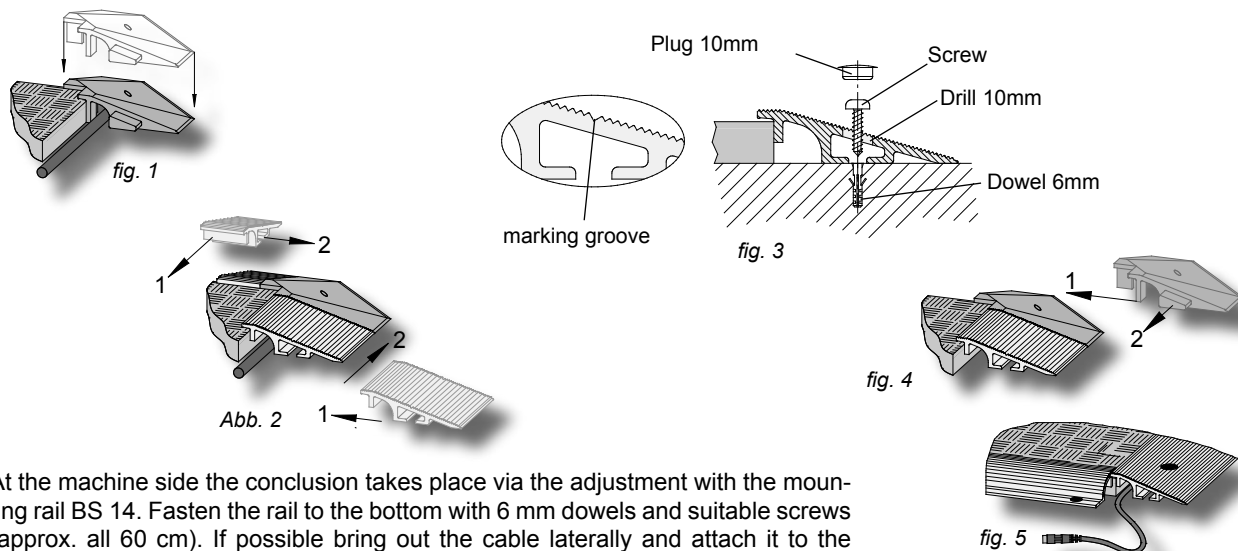

At the machine side the conclusion takes place via the adjustment with the mounting rail BS 14. Fasten the rail to the bottom with 6 mm dowels and suitable screws (approx. all 60 cm). If possible bring out the cable laterally and attach it to the controller (fig. 5).

Special notes on mounting for laying the metallic checkered covering made of either aluminum or stainless steel

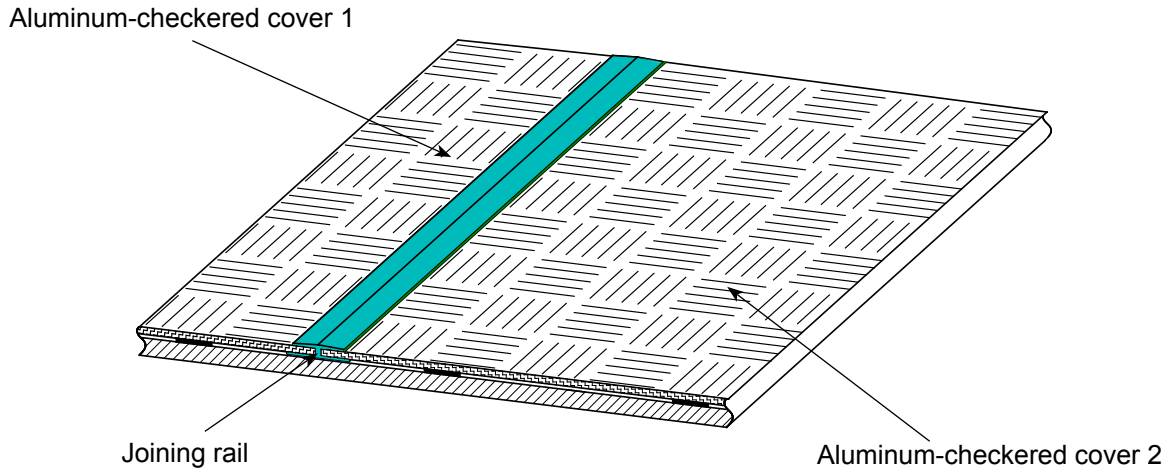

Date 06.06.2007

Technical information version 1.3
Technical changes reserved

It shall be noted for versions with metallic checkered coverings in aluminum (ARB) or stainless steel (TBV) that the coverings are connected together using a joining rail.

Please note for overmeasure

The area to be safeguarded are made up by the dimension of the safety contact mat. The dimensions of 62 mm (for the ramp rail) and 35 mm (for the mounting-rail) must be added to this. The sum gives the total area required. The mounting-rail and the ramp rail are required for holding the mat in position on the floor. The maximum size that can be manufactured is 2500 mm x 1400 mm. Sizes greater than this can be realized by sequencing single mats.

