

Safety relay JSBR4

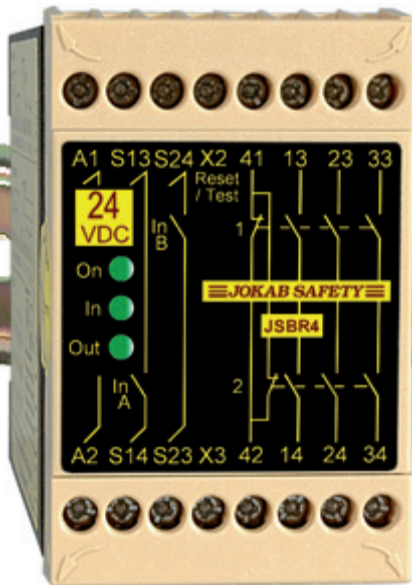

Approvals:



Safety relay for:

- Two-hand devices of type IIIc
- Emergency stop
- Three position devices
- Interlocked Gates/Hatches
- Contact strips
- Safety mats
- Foot operated switches

Features:

- Dual input channels synchronism 0.5 s
- Supervised reset
- Test input
- Width 45 mm
- LED indication for supply, inputs and outputs
- 3 NO/1NC relay outputs
- Supply 24 VDC, 24, 48, 115 or 230 VAC
- Quick release connector blocks

A universal relay for various safety and Two-hand devices

The JSBR4 has two inputs, which both have to be closed to keep the safety output contacts closed. A short-circuit across the inputs will cause the output contacts to open. The inputs can however be subjected to a continuous short-circuit without damaging the safety relay.

In order to make the safety outputs close the reset input must be closed and opened. In this way an unintentional reset is prevented in the case of a short-circuit in the reset button cable or if the button gets jammed in the actuated position. The reset input can also be used for test/supervision to ensure that contactors or valves have returned to their initial off/stop position before a new start can be allowed by the safety relay.

When the JSBR4 is used as a two-hand device relay, both buttons have to be pressed within 0.5 seconds of each other in order to close the outputs.

When the JSBR4 is used for Safety Mats and Safety Strips the "stop" condition is given following detection of a short-circuit between input channels A and B. The safety mat, safety strip or the relay will not be damaged by a continuous short-circuit. This also gives the advantage that if there is a failure between the inputs in the installation, the safety relay will not be damaged.

Safety level

The JSBR4 has a twin supervised safety function. Component failure, short-circuit or external disturbance (e.g. loss of power supply) will not prevent the safe function of

the relay. This is valid both for the inputs A and B as well as for the reset input. The JSBR4 operates at the highest safety level for safety relays (category 4).

Regulations and standards

The JSBR4 is designed and approved in accordance with appropriate directives and standards. Examples of such are 98/37/EC, EN ISO 12100-1/-2, EN 60204-1 and EN 954-1/EN ISO 13849-1. The JSBR4 complies with the highest safety level for the connection of a two-hand device of type IIIc in accordance with EN 574.

Connection examples

For examples of how our safety relays can solve various safety problems, please see the section "Connection examples".

Technical data - JSBR4

Manufacturer:	JOKAB SAFETY AB, Sweden
Colour:	Black and Beige
Power supply:	24 VDC +/- 15% 24/48/115/230 VAC +/- 15% , 50 - 60 Hz
Power consumption:	< 2 VA
Relay outputs:	3 NO + 1 NC
Maximum switching capacity res. load AC:	6A/250 VAC/1500 VA
Maximum switching capacity res. load DC:	6A/24 VDC/150 W
Max. res. load total switching capacity:	12A distributed on all contacts
Minimum load:	10mA/10 V (if load on contact has not exceeded 100 mA)
Contact material:	Ag + Au flash
Max. Input Wire res. at nom. voltage:	300 Ohm (S13 - S14 and S23 - S24)
Response time at deactivation:	< 20 ms (145 ms at power loss)
Terminals (Max. screw torque 1 Nm):	Single strand: 1 x 4 mm ² /2 x 1,5 mm ² . Conductor with socket contact: 1 x 2,5 mm ² /2 x 1 mm ² .
Mounting:	35 mm DIN-rail
Protection class enclosure/terminals:	IP 40/20 IEC 60529
Operating temperature range:	-10°C to +55°C
Air and creep distance:	4kV/2 DIN IEC 60664-1
LED indication:	Electrical Supply, Inputs, Outputs
Weight:	350 g (24 VDC), 460 g (24 - 230 VAC)

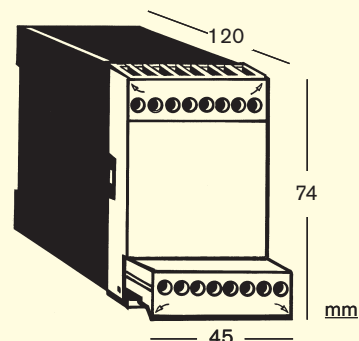

Connector blocks are detachable (without cables having to be disconnected)

Article number/Ordering data

10-002-00	24DC
10-002-02	24AC
10-002-03	48AC
10-002-04	115AC
10-002-05	230AC

Technical description - JSBR4

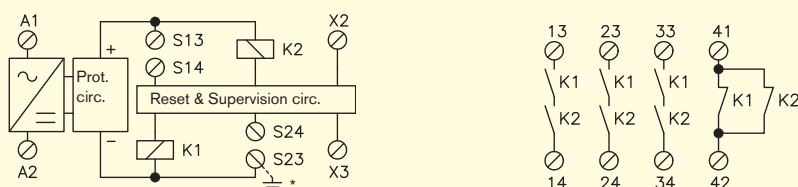

* Only for AC-supply

The electrical supply is connected across A1 and A2. After Voltage reduction and Rectification (AC-versions) or reverse polarity protection (DC-version) there is an overload protection-circuit.

When the inputs S13-S14 and S23-S24 have closed and the reset is made, the relays K1 and K2 are activated. A dual stop signal is given when K1 and

K2 drop, due to short circuiting between the inputs, opening of the inputs or power failure. If one input is opened the other input must also be opened for K1 and K2 to be activated again.

The monitoring circuit checks K1 and K2 and that the reset circuit to X2 is both closed and opened before K1 and K2 are energized. Both the stop and reset function therefore comply

with the requirement that a component fault, short circuit or external interference do not result in a dangerous function.

The safety outputs consist of contacts from K1 and K2 connected internally in series across terminals 13 - 14, 23 - 24 and 33 - 34. These contacts are used to cut the power to components which stop or prevent hazardous movements/functions. It is recommended that all switched loads are adequately suppressed and/or fused in order to provide additional protection for the safety contacts.

Note: Output 41-42 is intended for indication purposes only, e.g. gate opened. No load between S14 and S24 allowed.

Electrical connection - JSBR4

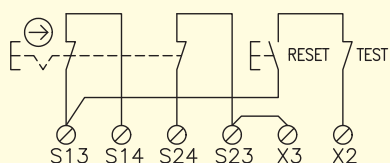

Emergency stop with manual resetting.

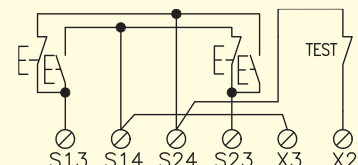

Two hand device with buttons in separate or same enclosure. Buttons to be pressed in within 0.5 s of each other. Footpedal switches can be connected in the same configuration.

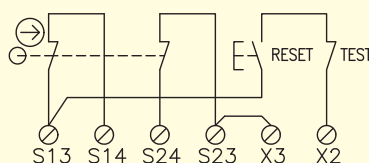

Interlocked gate with manual reset.

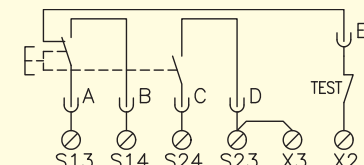

Enabling device, JSHD4. Stop condition is given in both top and bottom PB positions.

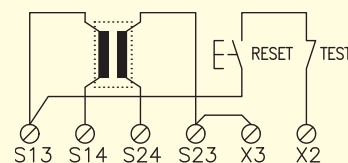

Contact mat/strip with manual reset.

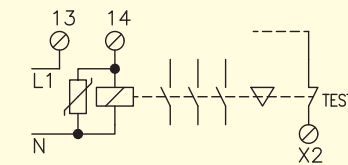

Control and supervision of external conductor, relay, valve or JOKAB SAFETY's expansion relays.