

URAX-A1, -A1R

AS-i safe input slave for dynamic sensors



General description

URAX-A1(R) is a safe input slave for AS-i bus intended for connection to dynamic sensors such as Jokab “Eden” sensors and “Tina” components. The models URAX-A1 and URAX-A1R are also equipped with a non-safe output. The AS-i bus is specified by the two organisations “AS-International Association” and “AS-Interface Safety at Work”, and is described in the publication “AS-Interface The Automatic Solution”.

Connections for URAX-A1

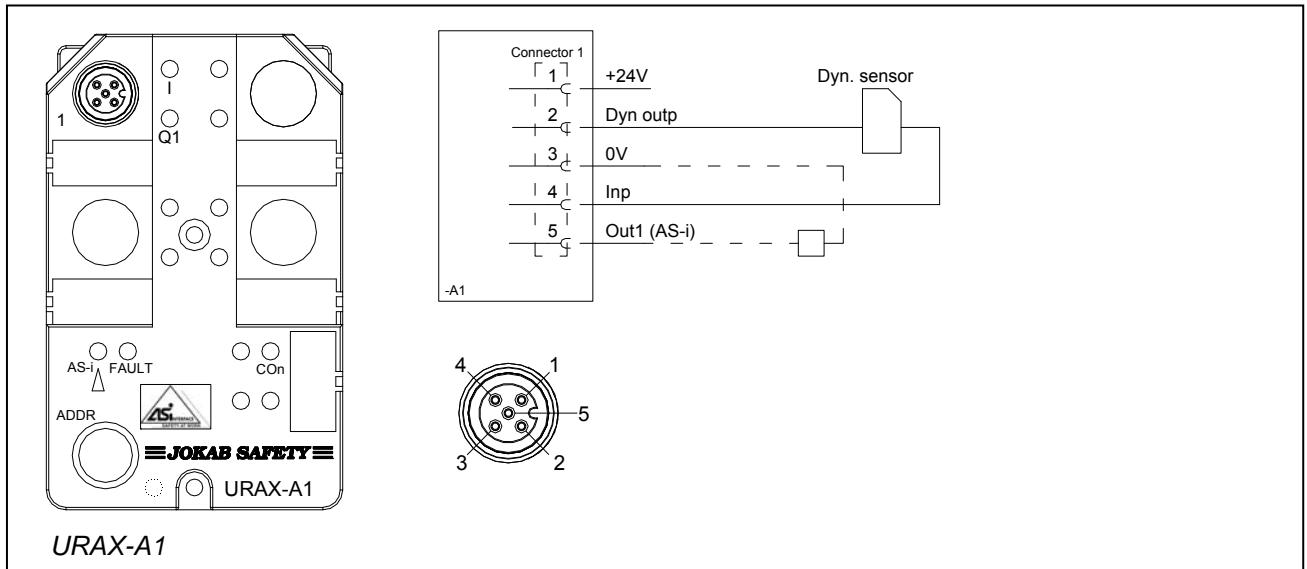

Connections for URAX-A1R

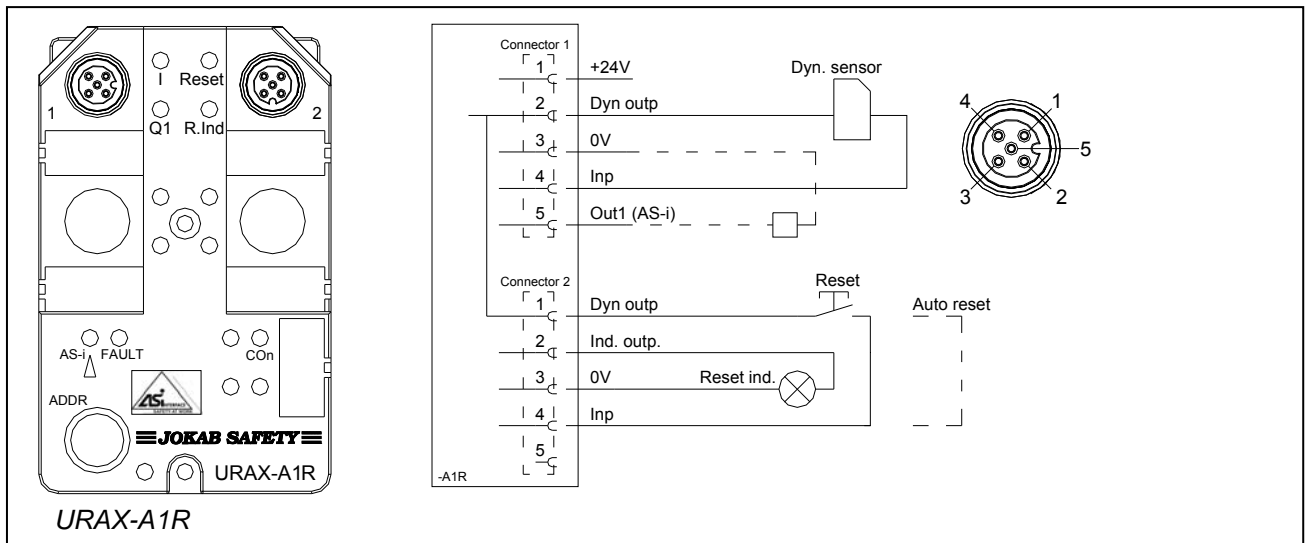

Reset

URAX-A1R has an input for local reset at connector 2 which can be configured via parameter setting for either auto reset or manual reset. (See table, Parameter settings and safety codes.)

Auto reset

If auto reset is selected pin 1-4 in connector 2 must be bridged.

Manual reset

If manual reset is selected the Reset input must switch on and off within 2 seconds in order to switch on the safety slave (generate safety code).

Odd or even number of sensors

The sensor concept is based on the safety principle of dynamic signals where each sensor inverts the signal. The concept makes it possible to detect failures such as short circuits and sensor faults. Since each sensor inverts the signal, the URAX-A1(R) must be configured for either an odd or even number of sensors. (See table, "Parameter settings and safety codes".)

Parameter settings and safety codes

P0: Number of sensors. Odd (1) / Even (0)

P1: Manual reset (1) / Auto reset (0)

Parameter					Function	Safety Code
Hex	P3	P2	P1	P0		
0	0	0	0	0	Auto Reset, Even number of sensors	Safety Code 1
1	0	0	0	1	Auto Reset, Odd number of sensors	Safety Code 2
					For A1R only:	
2	0	0	1	0	Manual Reset, Even number of sensors	Safety Code 3
3	0	0	1	1	Manual Reset, Odd number of sensors	Safety Code 4

Note: Unique Safety Code for each parameter setting. New "Code teach" procedure needs to be performed for Pluto AS-i or Safety monitor if the parameter setting has been changed.



LED indication

LED	Indication	Description
I (Input) Indication of input status	ON	Input signal accepted
	Flash	- Input fault. - Input signal present but not accepted. - Short circuit dynamic input to output (pin 2-4)
Q1 (Output) Indication of output status	ON	Output on
Reset Indication of Reset input status	ON	Reset input signal present.
	Fast flash	Reset input signal present but not accepted. Manual reset: - Reset is switched on before safety input is on. - Reset is pressed but more than 2 seconds. Auto reset: - Reset is switched on after safety input is on.
R.Ind (Reset indication output)	ON	Input signal not accepted
	Flash	Sensor signal accepted, waiting for reset
	Fast flash	Faulty reset. Manual reset: - Reset is switched on before safety input is on. - Reset is pressed but more than 2 seconds. Auto reset: Reset is switched on after safety input is on.
Con Indication of safety code generation	OFF	Safety slave is OFF. No safety code is generated.
	ON	The safety slave is switched ON and generates safety code.
	Flash	I/O fault, e.g. dynamic output signal short circuited
	Fast flash	I/O fault, CPU mismatch

AS-i LED and Fault LED in combination:

AS-i	Fault	
OFF	OFF	AS-i power missing
ON	OFF	Normal operation
ON	ON	No data exchange with master
Flash	ON	No data exchange because address = 0
Flash	Flash	Peripheral fault. Output overload.

Technical data

Technical data – URAX-A1(R)	
Manufacturer	JOKAB SAFETY AB
AS-i data	
AS-i profile URAX-A1(R)	S-7.B.E
Addressing	Connector
Slave address at delivery	0
Power supply	
Voltage	AS-i yellow cable, 30 V DC. Tolerance 26.5 - 31.6 V DC.
Insulation	0 V is common with – AS-i and may not be connected to protective earth. (AS-i power is floating.)
Total current consumption	<260mA (Own consumption, sensor and output)
Overall output current limit	180 mA (Sensor, output and reset indicator)
Output (non-safe)	
Output voltage	24-28V DC at nominal AS-i voltage, 30V.
	Depending on total load.
Current	See Total current consumption
General	
Reaction time (switch off)*	12 ms (excluding sensors and other peripheral components)
Reaction time including Eden sensors (Normal)	<20 ms
Reaction time including Eden sensors (Worst case)	<34 ms
Number of Eden sensors (max)	3
Total sensors cable length	<30 m
Degree of protection	IP67
Ambient temperature	-25...+65°C
Housing dimensions	96x60x25 (HxBxD)
Safety / Harmonized standards	
IEC/EN 61508-1..7	SIL3, PFD _{avr} : 1.5x10 ⁻⁴ , PFH: 1.7x10 ⁻⁹ , Share of SIL3: 15%
EN 62061	SIL3
EN ISO 13849-1	Performance level PLe, Category 4,
	MTTF _d : high
EN 954-1	Category 4
Certifications	TÜV Nord  

***Note:** The reaction time specified above is for the URAX unit itself. In the calculation of the total reaction time of the complete safety function all included components must be considered.

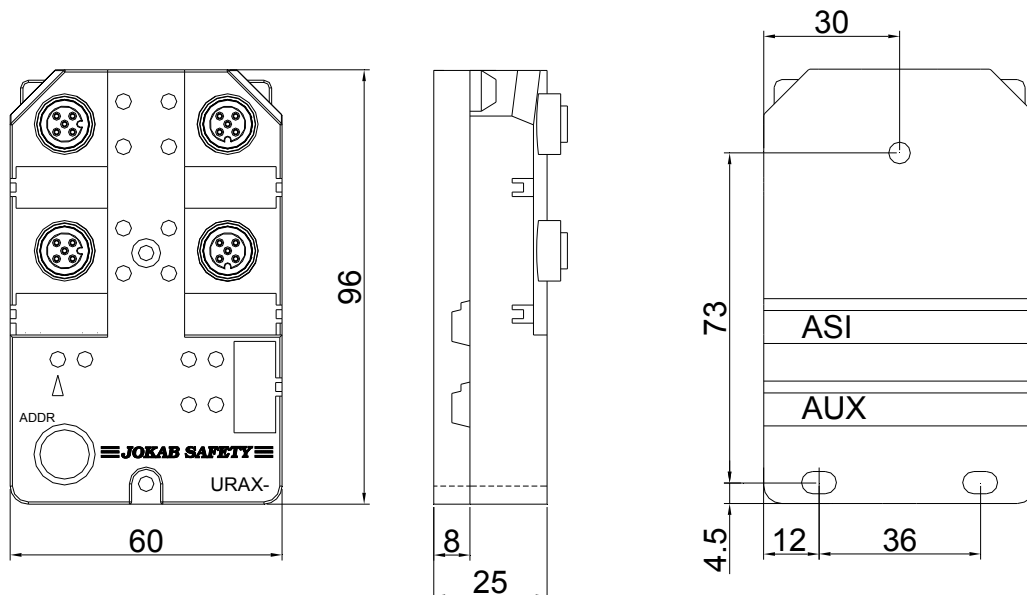

URAX-B1R

AS-i safe input slave for dynamic sensors



General description

URAX-B1R is a safe input slave for AS-i bus intended for connection to dynamic sensors such as Jokab “Eden” sensors and “Tina” components. URAX-B1R is also equipped with three non-safe outputs. The AS-i bus is specified by the two organisations “AS-International Association” and “AS-Interface Safety at Work”, and is described in the publication “AS-Interface The Automatic Solution”.

Connections for URAX-B1R

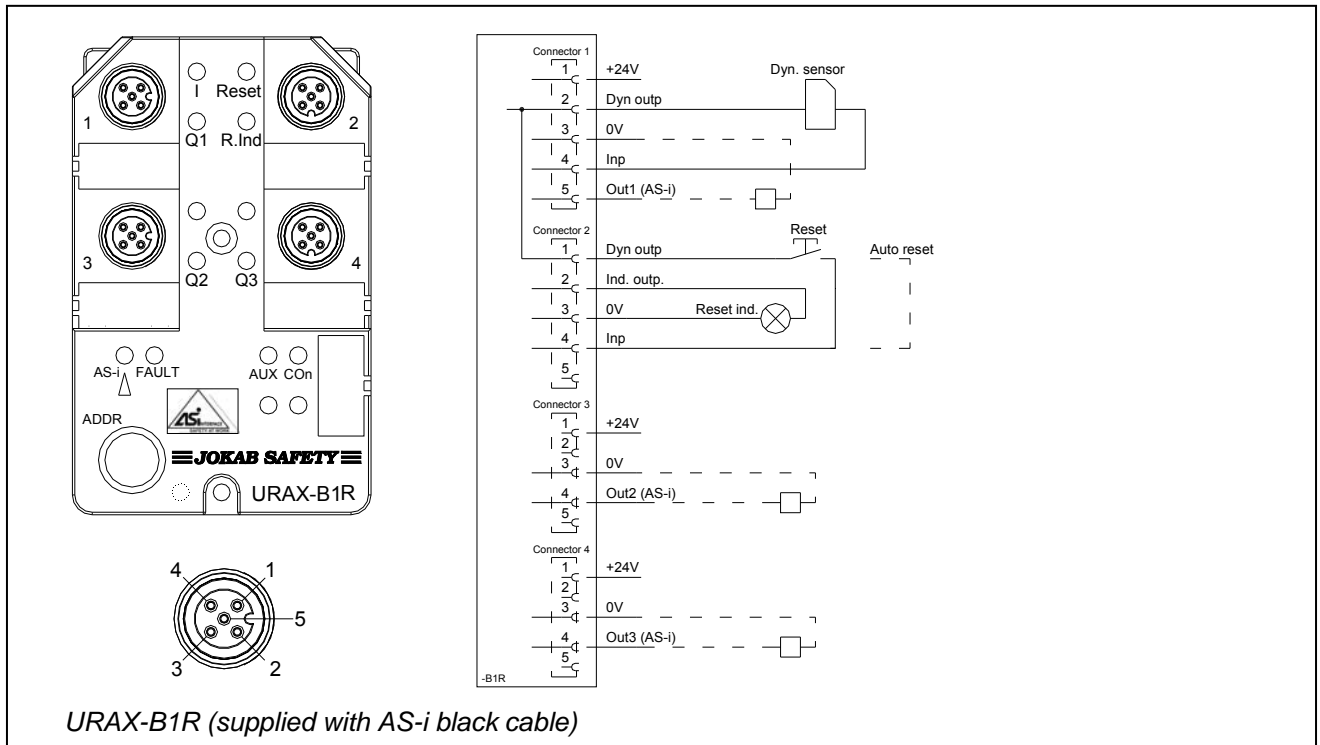

Reset

URAX-B1R has an input for local reset at connector 2 which can be configured via parameter setting for either auto reset or manual reset. (See table, Parameter settings and safety codes.)

Auto reset

If auto reset is selected pin 1-4 in connector 2 must be bridged.

Manual reset

If manual reset is selected the Reset input must switch on and off within 2 seconds in order to switch on the safety slave (generate safety code).

Odd or even number of sensors

The sensor concept is based on the safety principle of dynamic signals where each sensor inverts the signal. The concept makes it possible to detect failures such as short circuits and sensor faults. Since each sensor inverts the signal, URAX-B1R must be configured for either an odd or even number of sensors. (See table, "Parameter settings and safety codes".)

Parameter settings and safety codes

P0: Number of sensors. Odd (1) / Even (0)

P1: Manual reset (1) / Auto reset (0)

Parameter					Function	Safety Code
Hex	P3	P2	P1	P0		
0	0	0	0	0	Auto Reset, Even number of sensors	Safety Code 1
1	0	0	0	1	Auto Reset, Odd number of sensors	Safety Code 2
2	0	0	1	0	Manual Reset, Even number of sensors	Safety Code 3
3	0	0	1	1	Manual Reset, Odd number of sensors	Safety Code 4

Note: Unique Safety Code for each parameter setting. New "Code teach" procedure needs to be performed for Pluto AS-i or Safety monitor if the parameter setting has been changed.

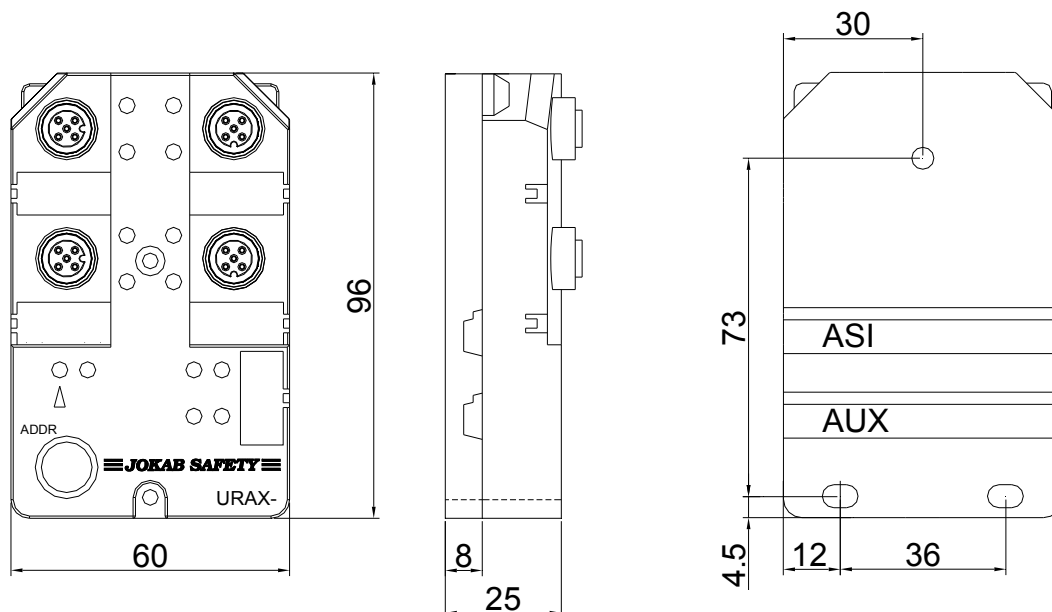



LED indication

LED	Indication	Description
I (Input) Indication of input status	ON	Input signal accepted
	Flash	- Input fault. - Input signal present but not accepted. - Short circuit dynamic input to output (pin 2-4)
Q1 (Output) Indication of output status	ON	Output on
Q2 (Output) Indication of output status	ON	Output on
Q3 (Output) Indication of output status	ON	Output on
Reset Indication of Reset input status	ON	Reset input signal present.
	Fast flash	Reset input signal present but not accepted. Manual reset: - Reset is switched on before safety input is on. - Reset is pressed but more than 2 seconds. Auto reset: - Reset is switched on after safety input is on.
R.Ind (Reset indication output)	ON	Input signal not accepted
	Flash	Sensor signal accepted, waiting for reset
	Fast flash	Faulty reset. Manual reset: - Reset is switched on before safety input is on. - Reset is pressed but more than 2 seconds. Auto reset: Reset is switched on after safety input is on.
AUX Indication of AUX power	OFF	No AUX power
	ON	AUX power is present
Con Indication of safety code generation	OFF	Safety slave is OFF. No safety code is generated.
	ON	The safety slave is switched ON and generates safety code.
	Flash	I/O fault, e.g. dynamic output signal short circuited
	Fast flash	I/O fault, CPU mismatch

AS-i LED and Fault LED in combination:

AS-i	Fault	
OFF	OFF	AS-i power missing
ON	OFF	Normal operation
ON	ON	No data exchange with master
Flash	ON	No data exchange because address = 0
Flash	Flash	Peripheral fault. Output overload.

Technical data

Technical data – URAX-B1R	
Manufacturer	JOKAB SAFETY AB
AS-i data	
AS-i profile URAX-B1R	S-7.B.E
Addressing	Connector
Slave address at delivery	0
Power supply	
Voltage AS-i (Yellow cable)	30 V DC. Tolerance 26.5 - 31.6 V DC.
Voltage AUX (Black cable)	24 V DC ($\pm 15\%$)
Insulation	0V is common with –AUX which shall be connected to protective earth at power supply.
Current limit (+24 V)	700 mA
Total current consumption AS-i	<30 mA
Outputs (non-safe)	
Output voltage	24V DC (AUX)
Current	700 mA
Reset indicator output	
Reset lamp (max)	2 W
General	
Reaction time (switch off)*	12 ms (excluding sensors and other peripheral components)
Reaction time including Eden sensors (Normal)	<20 ms
Reaction time including Eden sensors (Worst case)	<34 ms
Number of Eden sensors (max)	10
Total sensors cable length	<30 m
Degree of protection	IP67
Ambient temperature	-25...+65°C
Housing dimensions	96x60x25 (HxBxD)
Safety / Harmonized standards	
IEC/EN 61508-1..7	SIL3, PFD _{avr} : 1.5×10^{-4} , PFH: 1.7×10^{-9} , Share of SIL3: 15%
EN62061	SIL3
EN ISO 13849-1	Performance level PLe, Category 4,
EN 954-1	MTTFd: high Category 4
Certifications	TÜV Nord  

***Note:** The reaction time specified above is for the URAX unit itself. In the calculation of the total reaction time of the complete safety function all included components must be considered.

URAX-C1

AS-i safe input slave for dual channel with contacts



General description

URAX-C1 is a dual channel safe input slave for AS-i bus intended for connection to devices with contacts such as interlocking switches and emergency stops. The AS-i bus is specified by the two organisations “AS-International Association” and “AS-Interface Safety at Work”, and is described in the publication “AS-Interface The Automatic Solution”.

Connections for URAX-C1

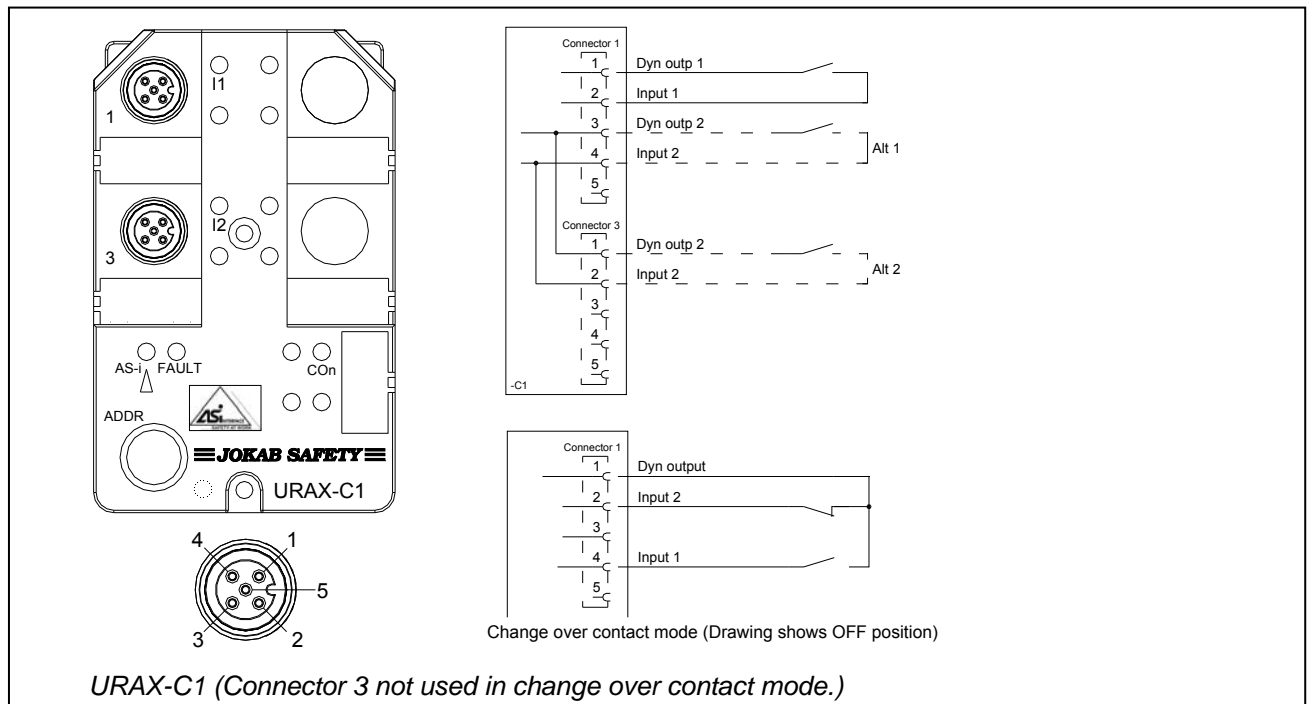

Dual channel inputs

URAX-C1 is intended for safety devices with dual channel contacts. The channels are supplied with individual dynamic signals in order to detect short circuits between the channels. It is possible to either use only connector 1 for a dual channel device, or connect both connector 1 and 3 to separate safety devices.

Change over contact mode

Via parameter setting URAX-C1 can either be set in “change over contact mode” (NO+NC) or NO+NO mode. (See table, Parameter settings and safety codes.)

Parameter settings and safety codes

P0: Inputs. NO+NO (1) / NO+NC (0)

Parameter					Function	Safety Code
Hex	P3	P2	P1	P0		
0	0	0	0	0	Input NO + NC	Safety Code 1
1	0	0	0	1	Input NO + NO	Safety Code 2

Note: Unique Safety Code for each parameter setting. New “Code teach” procedure needs to be performed for Pluto AS-i or Safety monitor if the parameter setting has been changed.



LED indication

LED	Indication	Description
I1 (Input 1) Indication of input status	ON	Input signal accepted
	Flash	- Input fault. - Input signal present but not accepted, or channel fault.
I2 (Input 2) Indication of input status	ON	Input signal accepted
	Flash	- Input fault. - Input signal present but not accepted, or channel fault.
Con Indication of safety code generation	OFF	Safety slave is OFF. No safety code is generated.
	ON	The safety slave is switched ON and generates safety code.
	Flash	I/O fault, e.g. dynamic output signal short circuited
	Fast flash	I/O fault, CPU mismatch

AS-i LED and Fault LED in combination:

AS-i	Fault	
OFF	OFF	AS-i power missing
ON	OFF	Normal operation
ON	ON	No data exchange with master
Flash	ON	No data exchange because address = 0
Flash	Flash	Peripheral fault. Output overload.

Technical data

Technical data – URAX-C1	
Manufacturer	JOKAB SAFETY AB
AS-i data	
AS-i profile URAX-C1	S-0.B.0
Addressing	Connector
Slave address at delivery	0
Power supply	
Voltage	AS-i yellow cable, 30 V DC (26.5 - 31.6)
Total current consumption	<150 mA
General	
Reaction time (switch off)*	12 ms (excluding sensors and other peripheral components)
Degree of protection	IP67
Ambient temperature	-25...+65°C
Housing dimensions	96x60x25 (HxBxD)
Safety / Harmonized standards	
IEC/EN 61508-1..7	SIL3, PFD _{avr} : 1.5x10 ⁻⁴ , PFH: 1.7x10 ⁻⁹ , Share of SIL3: 15%
EN62061	SIL3
EN ISO 13849-1	Performance level PLe, Category 4,
EN 954-1	MTTFd: high
	Category 4
Certifications	TÜV Nord  

***Note:** The reaction time specified above is for the URAX unit itself. In the calculation of the total reaction time of the complete safety function all included components must be considered.

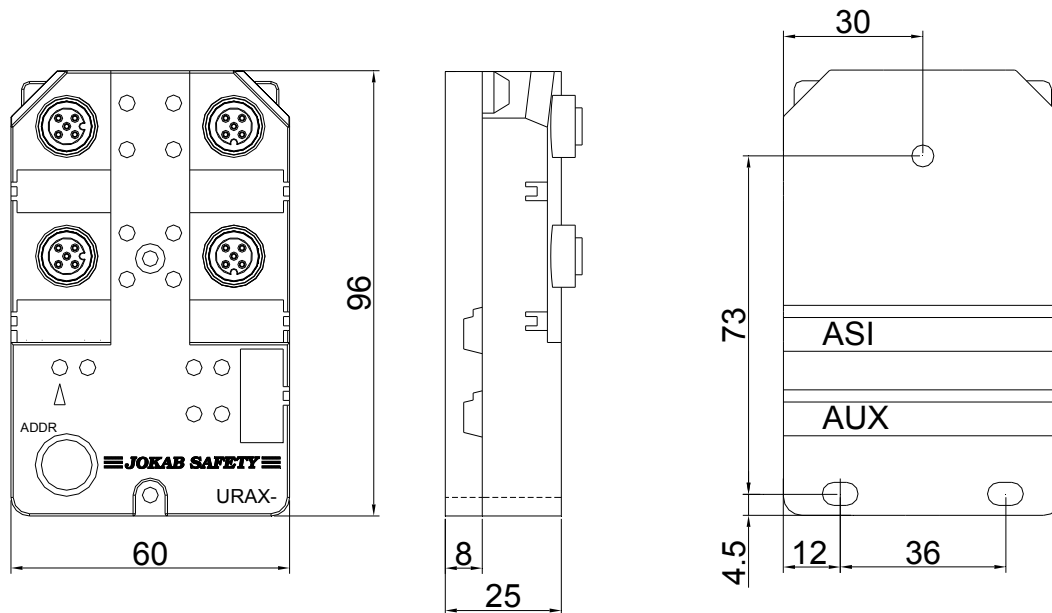

URAX-C1R

AS-i safe input slave for dual channel with contacts



General description

URAX-C1R is a dual channel safe input slave for AS-i bus intended for connection to devices with contacts such as interlocking switches and emergency stops. The AS-i bus is specified by the two organisations “AS-International Association” and “AS-Interface Safety at Work”, and is described in the publication “AS-Interface The Automatic Solution”.

Connections for URAX-C1R

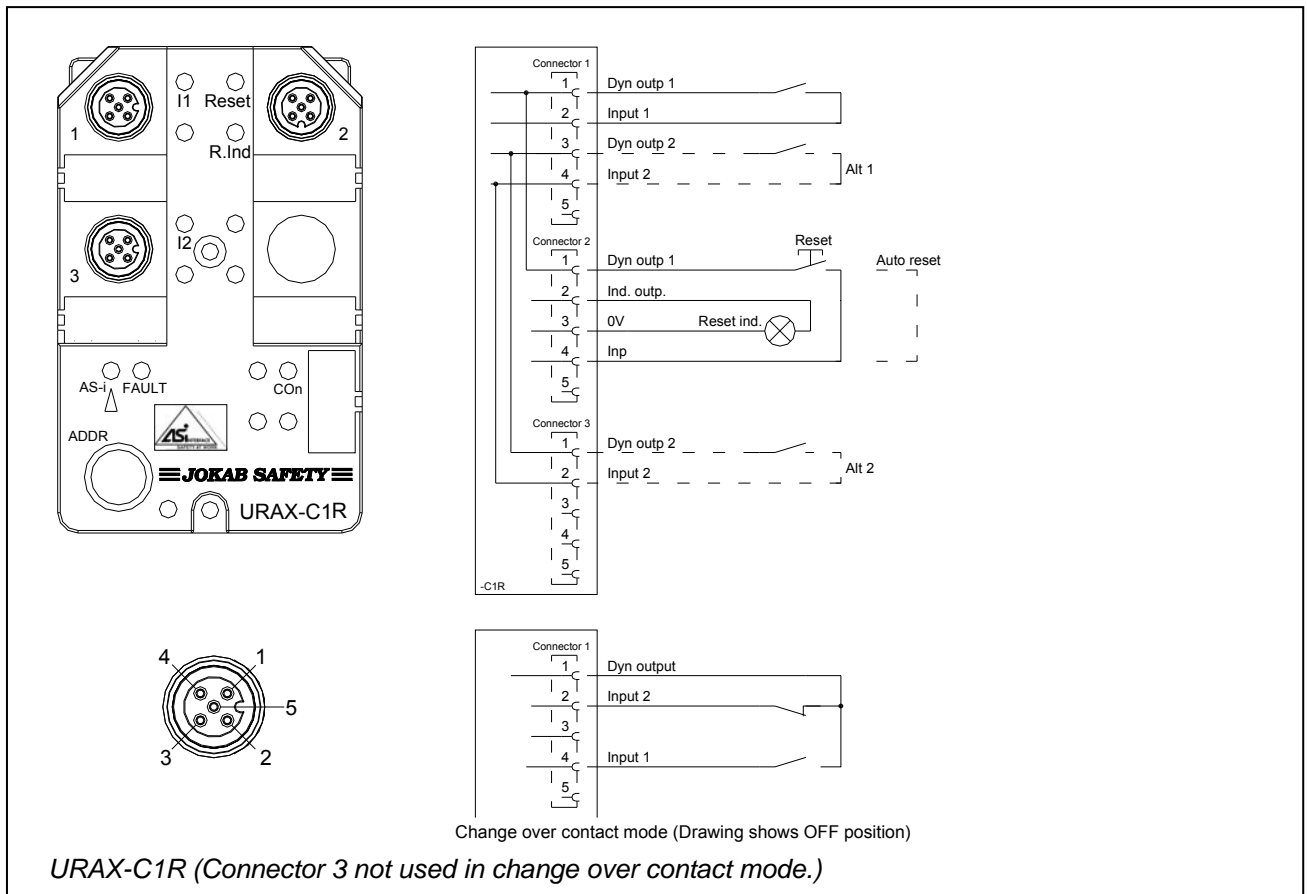

Reset

URAX-C1R has an input for local reset at connector 2 which can be configured via parameter setting for either auto reset or manual reset. (See table, Parameter settings and safety codes.)

Auto reset

If auto reset is selected pin 1-4 in connector 2 must be bridged.

Manual reset

If manual reset is selected the Reset input must switch on and off within 2 seconds in order to switch on the safety slave (generate safety code).

Dual channel inputs

URAX-C1R is intended for safety devices with dual channel contacts. The channels are supplied with individual dynamic signals in order to detect short circuits between the channels. It is possible to either use only connector 1 for a dual channel device, or connect both connector 1 and 3 to separate safety devices.

Change over contact mode

Via parameter setting URAX-C1R can either be set in “change over contact mode” (NO+NC) or NO+NO mode. (See table, Parameter settings and safety codes.)

Debounce function

URAX-C1R has a fixed “debounce” function, which is active in both reset and auto reset mode. After both channels (I1 and I2) have switched on, they are allowed to switch off/on during a “debounce time” of 1 second. In other words the channel monitoring is disabled during the debounce time.

Simultaneous operation time

When parameter P2 is set to 1 the two channels must be switched on within 2 seconds. (See table, Parameter settings and safety codes.)

Parameter settings and safety codes

P0: Sensor inputs. NO+NO (1) / NO+NC (0)

P1: Manual reset (1) / Auto reset (0)

P2: Simultaneous operation, 2 sec. (1) / No time limit (0)

Parameter					Function	Safety Code
Hex	P3	P2	P1	P0		
0	0	0	0	0	No time limit, Auto Reset, Input NO + NC	Safety Code 1
1	0	0	0	1	No time limit, Auto Reset, Input NO + NO	Safety Code 2
2	0	0	1	0	No time limit, Manual Reset, Input NO + NC	Safety Code 3
3	0	0	1	1	No time limit, Manual Reset, Input NO + NO	Safety Code 4
4	0	1	0	0	Simultaneous op., Auto Reset, Input NO + NC	Safety Code 5
5	0	1	0	1	Simultaneous op., Auto Reset, Input NO + NO	Safety Code 6
6	0	1	1	0	Simultaneous op., Manual Reset, Input NO + NC	Safety Code 7
7	0	1	1	1	Simultaneous op., Manual Reset, Input NO + NO	Safety Code 8

Note: Unique Safety Code for each parameter setting. New "Code teach" procedure needs to be performed for Pluto AS-i or Safety monitor if the parameter setting has been changed.

LED indication

LED	Indication	Description
I1 (Input 1) Indication of input status	ON	Input signal accepted
	Flash	- Input fault. - Input signal present but not accepted, or channel fault.
I2 (Input 2) Indication of input status	ON	Input signal accepted
	Flash	- Input fault. - Input signal present but not accepted, or channel fault.
Reset Indication of Reset input status	ON	Reset input signal present.
	Fast flash	Reset input signal present but not accepted. Manual reset: - Reset is switched on before safety input is on. - Reset is pressed but more than 2 seconds. Auto reset: - Reset is switched on after safety input is on.
R.Ind (Reset indication output)	ON	Input signal not accepted
	Flash	Sensor signal accepted, waiting for reset
	Fast flash	Faulty reset. Manual reset: - Reset is switched on before safety input is on. - Reset is pressed but more than 2 seconds. Auto reset: Reset is switched on after safety input is on.
Con Indication of safety code generation	OFF	Safety slave is OFF. No safety code is generated.
	ON	The safety slave is switched ON and generates safety code.
	Flash	I/O fault, e.g. dynamic output signal short circuited
	Fast flash	I/O fault, CPU mismatch

AS-i LED and Fault LED in combination:

AS-i	Fault	
OFF	OFF	AS-i power missing
ON	OFF	Normal operation
ON	ON	No data exchange with master
Flash	ON	No data exchange because address = 0
Flash	Flash	Peripheral fault. Output overload.

Technical data

Technical data – URAX-C1R	
Manufacturer	JOKAB SAFETY AB
AS-i data	
AS-i profile URAX-C1R	S-0.B.0
Addressing	Connector
Slave address at delivery	0
Power supply	
Voltage	AS-i yellow cable, 30 V DC (26.5 - 31.6)
Total current consumption	<150 mA
General	
Reaction time (switch off)*	12 ms (excluding sensors and other peripheral components)
Degree of protection	IP67
Ambient temperature	-25...+65°C
Housing dimensions	96x60x25 (HxBxD)
Safety / Harmonized standards	
IEC/EN 61508-1..7	SIL3, PFD _{avr} : 1.5x10 ⁻⁴ , PFH: 1.7x10 ⁻⁹ , Share of SIL3: 15%
EN62061	SIL3
EN ISO 13849-1	Performance level PL _e , Category 4,
EN 954-1	MTTF _d : high
	Category 4
Certifications	TÜV Nord

***Note:** The reaction time specified above is for the URAX unit itself. In the calculation of the total reaction time of the complete safety function all included components must be considered.

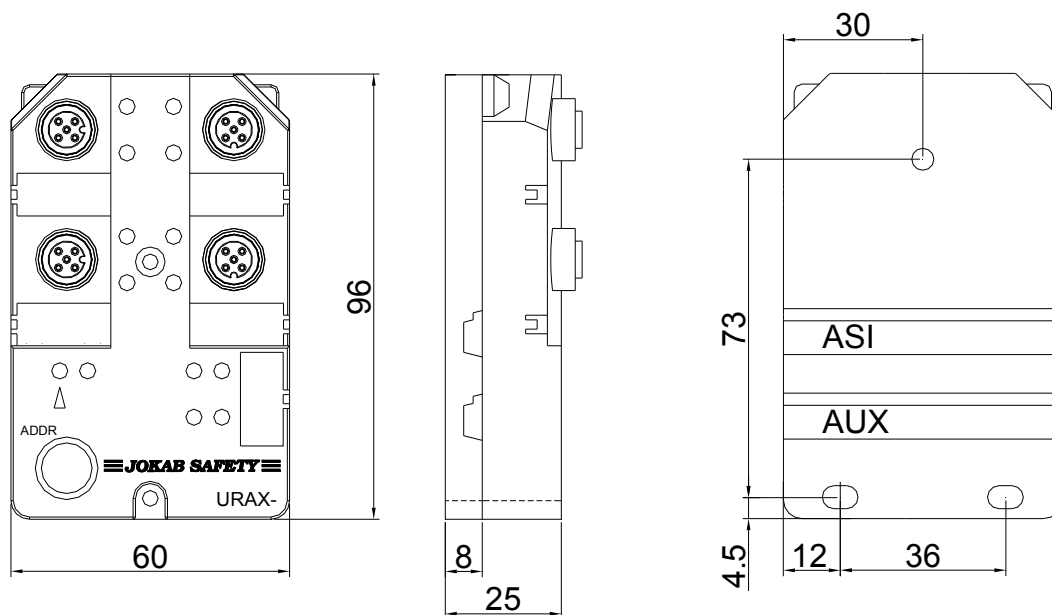

URAX-D1R

AS-i safe input slave for dual channel, solid state (OSSD)



General description

URAX-D1R is a dual channel safe input slave for AS-i bus intended for connection to safety devices with transistor outputs (OSSD). Examples of such devices are light curtains, light beams and scanners. URAX-D1R is also equipped with 3 non-safe outputs. The AS-i bus is specified by the two organisations “AS-International Association” and “AS-Interface Safety at Work”, and is described in the publication “AS-Interface The Automatic Solution”.

Connections for URAX-D1R

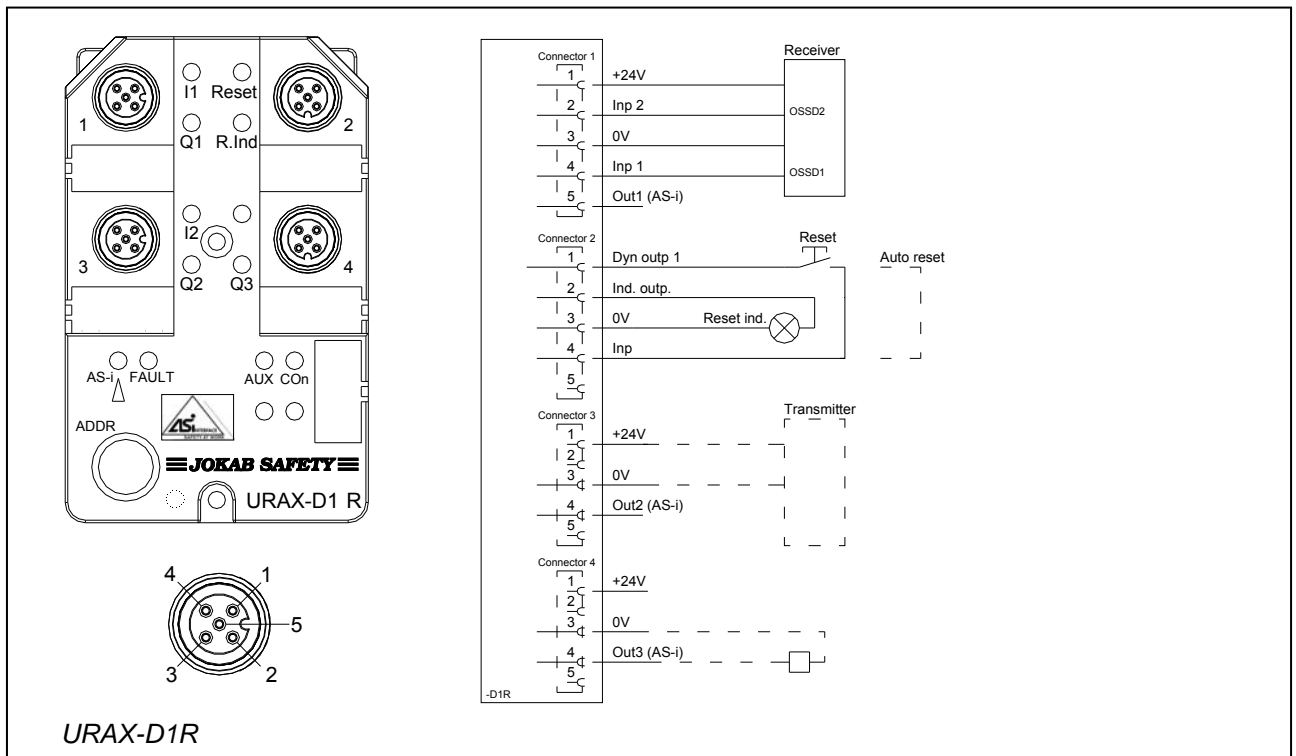

Reset

URAX-D1R has an input for local reset at connector 2 which can be configured via parameter setting for either auto reset or manual reset. (See table, Parameter settings and safety codes.)

Auto reset

If auto reset is selected pin 1-4 in connector 2 must be bridged.

Manual reset

If manual reset is selected the Reset input must switch on and off within 2 seconds in order to switch on the safety slave (generate safety code).

Short circuit detection (test pulses)

The safety device connected to URAX must be able to detect a short circuit between the channels as well as a short circuit to the supply voltage. These kinds of faults will not be detected by URAX! The usual way for a safety device to detect this is by applying test pulses on its OSSD output signals.

Detection of test pulses

URAX-D1R can be configured to detect if test pulses are being sent from the OSSD device or not (see table, "Parameter settings and safety codes"). If Test pulse detection is selected URAX will switch off unless these test pulses are present.

Parameter settings and safety codes

P1: Manual reset (1) / Auto reset (0)

P2: No test pulse detection (1) / Test pulse detection (0)

Parameter					Function	Safety Code
Hex	P3	P2	P1	P0		
0	0	0	0	0	Auto Reset, Test pulse detection	Safety Code 1
4	0	1	0	0	Auto Reset, No test pulse detection	Safety Code 2
					For -D1R only:	
2	0	0	1	0	Manual Reset, Test pulse detection	Safety Code 3
6	0	1	1	0	Manual Reset, No test pulse detection	Safety Code 4

Note: Unique Safety Code for each parameter setting. New "Code teach" procedure needs to be performed for Pluto AS-i or Safety monitor if the parameter setting has been changed.

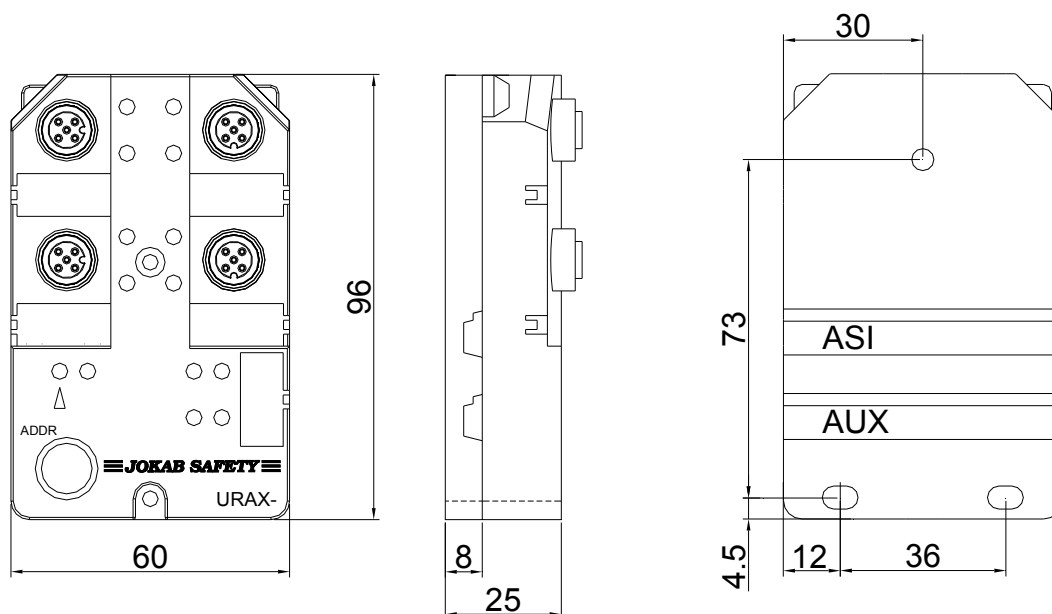



LED indication

LED	Indication	Description
I1 (Input) Indication of input status	ON	Input signal accepted
	Flash	- Input fault. - Input signal present but not accepted.
I2 (Input) Indication of input status	ON	Input signal accepted
	Flash	- Input fault. - Input signal present but not accepted.
Q1 (Output) Indication of output status	ON	Output on
Q2 (Output) Indication of output status	ON	Output on
Q3 (Output) Indication of output status	ON	Output on
Reset Indication of Reset input status.	ON	Reset input signal present.
	Fast flash	Reset input signal present but not accepted. Manual reset: - Reset is switched on before safety input is on. - Reset is pressed but more than 2 seconds. Auto reset: - Reset is switched on after safety input is on.
R.ind (Reset indication output)	ON	Input signal not accepted
	Flash	Sensor signal accepted, waiting for reset
	Fast flash	Faulty reset. Manual reset: - Reset is switched on before safety input is on. - Reset is pressed but more than 2 seconds. Auto reset: Reset is switched on after safety input is on.
AUX Indication of AUX power	OFF	No AUX power
	ON	AUX power is present
Con Indication of safety code generation	OFF	Safety slave is OFF. No safety code is generated.
	ON	The safety slave is switched ON and generates safety code.
	Fault	I/O fault, e.g. dynamic output signal short circuited
	Fast flash	I/O fault, CPU mismatch

AS-i LED and Fault LED in combination:

AS-i	Fault	
OFF	OFF	AS-i power missing
ON	OFF	Normal operation
ON	ON	No data exchange with master
Flash	ON	No data exchange because address = 0
Flash	Flash	Peripheral fault. Output overload.

Technical data

Technical data – URAX-D1R	
Manufacturer	JOKAB SAFETY AB
AS-i data	
AS-i profile URAX-D1R	S-7.B.E
Addressing	Connector
Slave address at delivery	0
Power supply	
Voltage AS-i (Yellow cable)	30 V DC. Tolerance 26.5 - 31.6 V DC.
Voltage AUX (Black cable)	24 V DC ($\pm 15\%$)
Insulation	0V is common with –AUX which shall be connected to protective earth at power supply.
Current limit (+24 V)	700 mA
Total current consumption AS-i	<30 mA
Outputs (non-safe)	
Output voltage	24V DC (AUX)
Current	700 mA
Reset indicator output	
Reset lamp (max)	2 W
General	
Reaction time (switch off)*	12 ms (excluding sensors and other peripheral components)
Test pulse detection:	
Pulse length	$\geq 20 \mu\text{s}$, below 10 V
Degree of protection	IP67
Ambient temperature	-25...+65°C
Housing dimensions	96x60x25 (HxBxD)
Safety / Harmonized standards	
IEC/EN 61508-1..7	SIL3, PFD _{avr} : 1.5×10^{-4} , PFH: 1.7×10^{-9} , Share of SIL3: 15%
EN62061	SIL3
EN ISO 13849-1	Performance level PLe, Category 4, MTTFd: high
EN 954-1	Category 4
Certifications	TÜV Nord  

***Note:** The reaction time specified above is for the URAX unit itself. In the calculation of the total reaction time of the complete safety function all included components must be considered.

URAX-E1

AS-i safe input slave for two-hand control



General description

URAX-E1 is a safe input AS-i slave module intended for connection to two-hand control devices according to EN 574 type IIIC. The AS-i bus is specified by the two organisations “AS-International Association” and “AS-Interface Safety at Work”, and is described in the publication “AS-Interface The Automatic Solution”.

Connections for URAX-E1

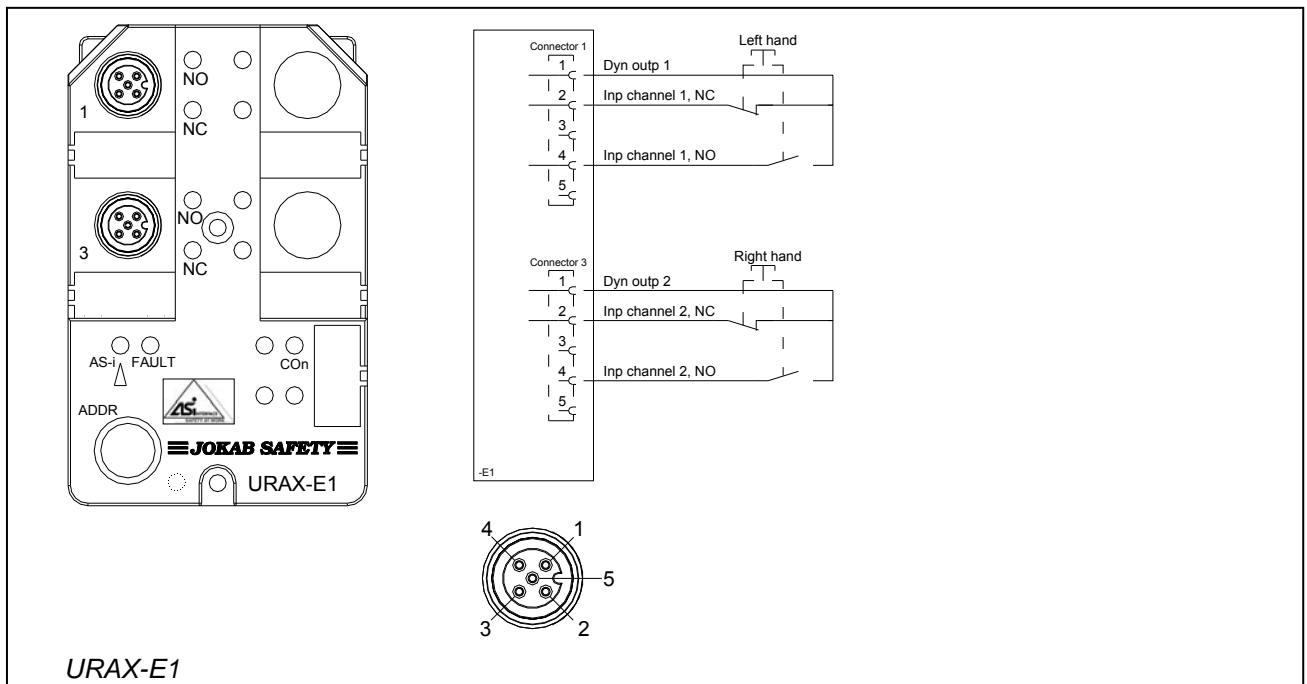

Inputs for two-hand control devices

URAX-E1 has two inputs for each hand / button, one normally open and one normally closed. To start (give AS-i code) all four inputs must switch from OFF to ON state within 0.5 seconds. Each input is monitored so if URAX switches off, all inputs must go to OFF state before a restart. (OFF state for a NC input is closed contact and open contact for a NO input.)



LED indication

LED	Indication	Description
NO (Input channel 1) Indication of input status	ON	Input signal accepted
	Flash	- Input fault. - Input signal present but not accepted, or channel fault.
NC (Input channel 1) Indication of input status	ON	Input signal accepted
	Flash	- Input fault. - Input signal present but not accepted, or channel fault.
NO (Input channel 2) Indication of input status	ON	Input signal accepted
	Flash	- Input fault. - Input signal present but not accepted, or channel fault.
NC (Input channel 2) Indication of input status	ON	Input signal accepted
	Flash	- Input fault. - Input signal present but not accepted, or channel fault.
Con Indication of safety code generation	OFF	Safety slave is OFF. No safety code is generated.
	ON	The safety slave is switched ON and generates safety code.
	Flash	I/O fault, e.g. dynamic output signal short circuited
	Fast flash	I/O fault, CPU mismatch

AS-i LED and Fault LED in combination:

AS-i	Fault	
OFF	OFF	AS-i power missing
ON	OFF	Normal operation
ON	ON	No data exchange with master
Flash	ON	No data exchange because address = 0
Flash	Flash	Peripheral fault. Output overload.

Technical data

Technical data – URAX-E1	
Manufacturer	JOKAB SAFETY AB
AS-i data	
AS-i profile URAX-E1	S-0.B.E
Addressing	Connector
Slave address at delivery	0
Parameter setting	0 (1...F reserved)
Power supply	
Voltage	AS-i yellow cable, 30 V DC (26.5 - 31.6)
Total current consumption	<150 mA
General	
Reaction time (switch off)*	12 ms (excluding sensors and other peripheral components)
Degree of protection	IP67
Ambient temperature	-25...+65°C
Housing dimensions	96x60x25 (HxBxD)
Safety / Harmonized standards	
IEC/EN 61508-1..7	SIL3, PFD _{avr} : 1.5x10 ⁻⁴ , PFH: 1.7x10 ⁻⁹ , Share of SIL3: 15%
EN62061	SIL3
EN ISO 13849-1	Performance level PLe, Category 4,
	MTTFd: high
EN 574	Type IIIC
Certifications	TÜV Nord  

***Note:** The reaction time specified above is for the URAX unit itself. In the calculation of the total reaction time of the complete safety function all included components must be considered.

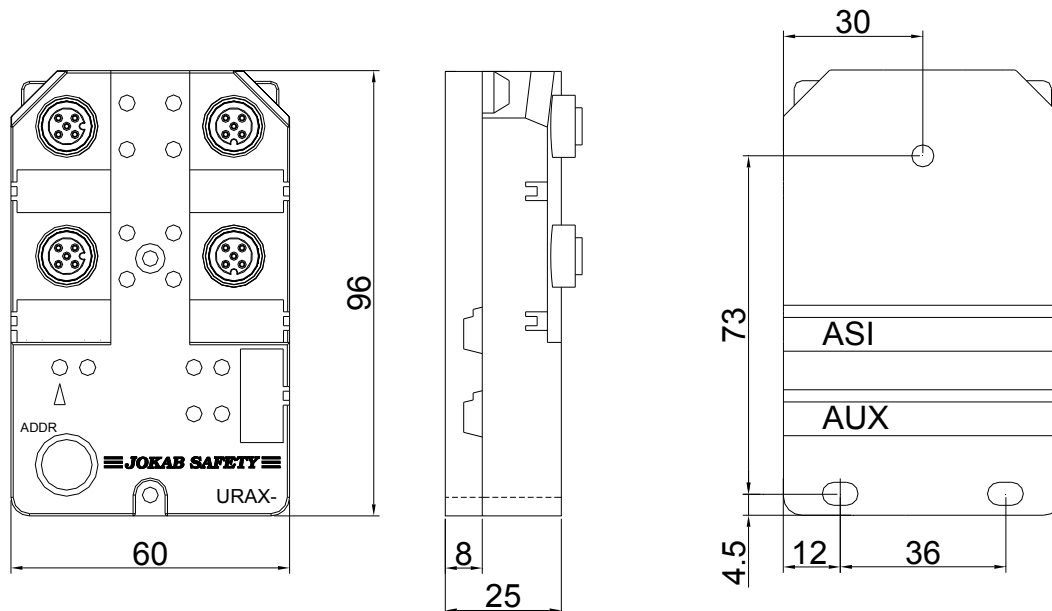

EC declaration of conformity

We JOKAB SAFETY AB declare that the safety components of JOKAB SAFETY
Kanalvägen 17 manufacture, with type designations and safety functions
183 30 Täby as listed below, are in conformity with the Directives
Sweden 2006/42/EC, (98/37/EC) and 2004/108/EC

Logic units to ensure safety functions [AS Interface safety slave URAX] intended to evaluate electrical sensors.

Type designations: URAX-A1, -A1R, -B1R, -C1, -C1R, -D1R and -E1.

Batch numbers: 01-00000...99-99999

Applicable harmonized standards EN 62061, EN ISO 13849-1, EN 574,
EN 60204-1, EN 50178,
EN 61000-4-2, -3, -4, -5, -6
EN 55011

Other applicable standards and documents IEC/EN 61508-1..7

EC Type-Examination TÜV NORD CERT GmbH
Langemarckstrasse 20, D-45141 Essen
Notified body No. 0044

Certificate no 44 205 09 554683 000

Compiler of technical file Göran Svensson, Kanalvägen 17, 183 30 Täby, Sweden
Kungsbacka 2009-11-05 Malmö 2009-11-05



Mats Linger
President



Torgny Olsson
Vice President

JOKAB SAFETY AB Kanalvägen 17, SE - 183 30 Täby, Sweden

www.jokabsafety.com