

AMS 3 AKAS Muting System

CONTENTS:**Safety instructions****Application notes****Installation****Electrical connection****Commissioning****Technical specifications****Accessories**

Chapter	Contents	Page
1.	Safety instructions 	3
2.	Device overview / Features / Mounting	4
3.	Description of operation modes	5
4.	Electrical connection	6
4.1	Magnet scale sensors with AMS3	-
4.2	AMS3 with AKAS 3 F	-
4.3	AMS3 with AKAS II F.....	7
4.4	AMS3 with AKAS LC F	-
5.	Technical data	8
6.	Faults / Possible causes / Remedies	8
7.	Service	9
8.	Documentation of mode settings	10



All safety instructions are marked with this symbol and must be observed in particular!

Safe functionality of the entire installation is guaranteed only if this operating manual and applicable accident-prevention regulations are observed. Forming part of the controller's scope of delivery, this operating manual must be kept at the controller's site of use.

All instructions in this operating manual must be strictly observed. The manual provides the user with important information concerning proper use of the AMS safety controller. Before commissioning the AKAS... F safety light curtains with the AMS safety controller, make sure to read both operating manuals.

Observe applicable standards and guidelines when using safety light curtains. Local authorities or trade associations will provide you with the relevant information. All other applicable regulations and standards issued by employers' liability insurance associations must be observed too.

Qualified personnel Installation, commissioning and maintenance must only be carried out by qualified personnel.



AMS is sensitive to electrostatic discharge. If you change the operation mode or the wiring please take care to discharge any electricity in your body by touching the metal frame or cabinet of the machine.



On request by the customer, Fiessler Elektronik carries out the acceptance test and annual inspections. In addition, seminars providing customers with training in annual inspections are held at regular intervals.

The AMS 3 provides the muting signal according to safety class 4 and the control signals for the AKAS F series. To get the information about movement direction and speed, the AMS 3 is using the signals from two magnet scale sensors. One sensor on each side of the machine. AMS 3 measures and evaluates speed, course and direction of the closing and opening movement of the press.

Furthermore it can measure the overrun traverse during the first stroke of the machine in combination with the FUS/FUO input of AKAS F series.

AMS can be used for AKAS LC F, AKAS II F and AKAS 3 F. The different operation modes can be selected with two DIP-switch.

The AMS 3 is especially designed to reduce the time for installing AKAS F series and to be able to mount AKAS without having position monitored valves for slow speed (working speed).

A complete set consists of the main unit AMS 3, two magnet scale sensors, 2 x 0,5m magnetic tape (self adhesive) and 2 x 0,5m aluminium profile to cover the magnetic tape.

The AMS 3 must be mounted inside the switch cabinet of the protective type IP54. It can be mounted on a DIN rail.

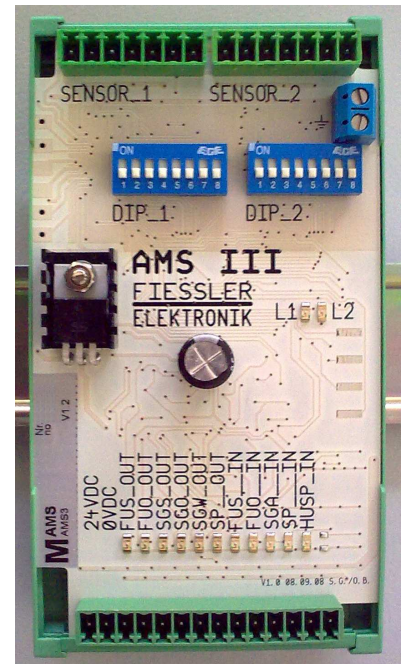

The magnetic tapes should be mounted on the ram (on presses with underneath drive it will be the bottom platen of the press). They must be fixed vertically. The length of the magnetic tapes must be as long as the maximum length of stroke plus 20 mm reserve at each end of both tapes.
Example: maximum stroke of the press without tool: 300mm + 2 x 20mm reserve = 340mm overall length of the magnetic tape.

The magnetic sensors must be mounted vertically on the machine. The sensor surface shall be placed directly above the magnetic tape with a maximum distance of 2mm to the tape.
The sensor can be fastened by using 2 screws M3 in the \varnothing 3,4 mm clearance holes.
The cable outlet should point to the bottom.

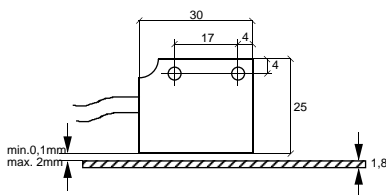
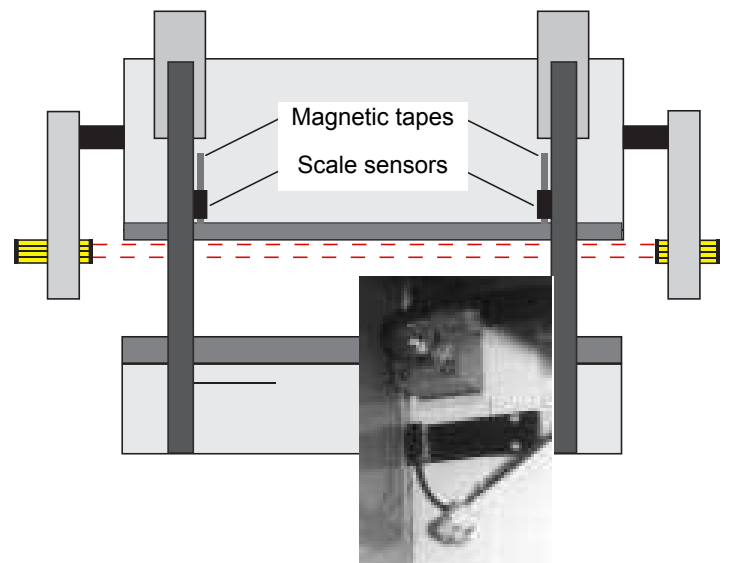

cable outlet

2,0 mm (maximum distance between tape / sensor)
Diameter clearance holes = 3,4mm (all dimensions in mm)

The aluminium profile should be mounted to protect the magnetic tape as following:

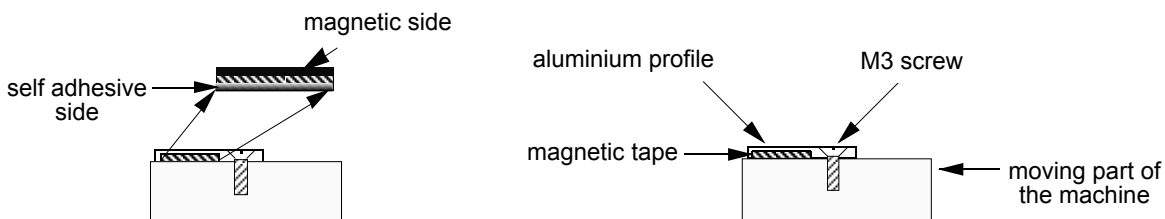

Avoid any unwanted influences of magnetic fields. In particular, all sorts of magnetic fields (e.g. from magnetic clamps or from similar permanent magnetic materials) must be kept away from direct contact with the magnetic tape.

The AMS can be used with AKAS LC F, AKAS II F, and AKAS 3 F. You can also select if AMS3 should do the overrun measurement at the first stroke. If AKAS II or AKAS 3 is selected, it is possible to set the max. allowed overrun to increase the performance of the machine. Values for the overrun:

AKAS LC max 15mm (fixed value, dipswitches 3, 4 and 5 not in use)

AKAS II 5mm to 14mm

AKAS3 4mm to 13mm



On AKAS II F and AKAS 3 F, the dipswitches in the receiver support **must** be switched accordingly.
 Example : AMS 3 = off, off, off, off, off, off, off, on => 50mm fast down, **13mm max. overrun**, AKAS3, overrun active.
 AKAS3 dipswitch setting = off, off, off => **13mm overrun**

To be able to work also with short stroke machines, you can determine the distance before AMS3 will stop the machine.

Highspeed down movement before STOP:

20mm up to 50mm in 10mm steps.



You can also deactivate the overrun measurement if you don't need this funktion.
 This should only be done if the machine is doing a safe overrun measurement on it's own.
For a safe operation you must have a safe overrun measurement at the first stroke.

The mode selection will be done with

two 8-pole dipswitch.

Both **must** be set to the same operation mode.

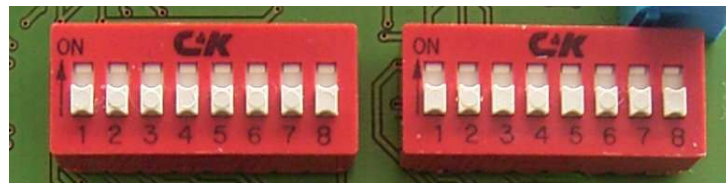

Dip 1	Dip 2	Dip 3	Dip 4	Dip 5	Dip 6	Dip 7	Dip 8	Operation mode
					OFF	OFF		AKAS 3 F
					OFF	ON		AKAS II F
					ON	OFF		AKAS LC F
							OFF	without overrun measurement
							ON	with overrun measurement
The following modes are only possible if overrun measurement is active								
OFF	OFF							50mm fast down movement before overrun measurement starts
OFF	ON							40mm fast down movement before overrun measurement starts
ON	OFF							30mm fast down movement before overrun measurement starts
ON	ON							20mm fast down movement before overrun measurement starts
The following modes are for AKAS 3 F								
		OFF	OFF	OFF				13mm maximum overrun
		OFF	OFF	ON				11mm maximum overrun
		OFF	ON	OFF				9mm maximum overrun
		ON	OFF	OFF				8mm maximum overrun
		OFF	ON	ON				7mm maximum overrun
		ON	OFF	ON				6mm maximum overrun
		ON	ON	OFF				5mm maximum overrun
		ON	ON	ON				4mm maximum overrun
The following modes are for AKAS II F								
		OFF	OFF	OFF				14mm maximum overrun
		OFF	OFF	ON				12mm maximum overrun
		OFF	ON	OFF				10mm maximum overrun
		ON	OFF	OFF				9mm maximum overrun
		OFF	ON	ON				8mm maximum overrun
		ON	OFF	ON				7mm maximum overrun
		ON	ON	OFF				6mm maximum overrun
		ON	ON	ON				5mm maximum overrun

4.1 Connecting the magnet scale sensors to AMS3

Connecting the two magnet scale sensors to the 7-pole connectors:

+Ub 24V DC	brown		1
0V	white		2
sensor B	yellow		3
sensor /B	orange		4
sensor A	green		5
sensor /A	violett		6
cable shield			7

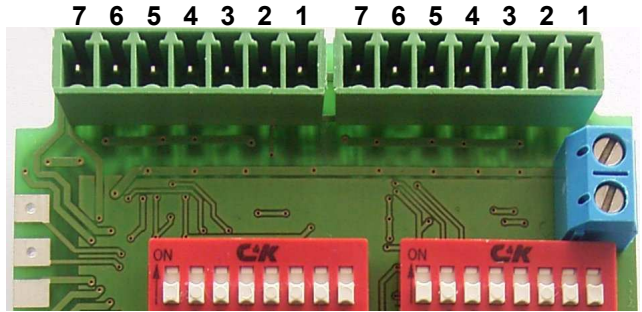

If you have mounted the magnet scale sensors with the cable outlet on top, you have to change A with B and /A with /B. Else the counting direction is not correct and AMS3 will not mute AKAS. Also if you have an upstroke acting machine, sensor channels have to be changed.

4.2 Connecting AMS3 to AKAS 3 F

	+Ub 24V DC		1
	-Ub 0V		2
output	24V if FUS_I is HIGH 0V if FUS_I is LOW	FUS_O	3
output	24V if FUO_I is HIGH 0V if FUO_I is LOW	FUO_O	4
output	24V if AMS detects slowspeed down 0V if highspped down or stop	SGS	5
output	0V if AMS detects slowspeed down 24V if highspped down or stop	SGO	6
output	24V if AMS detects slowspeedway 0V if highspped down or stop	SGW	7
output	24V inside slowspeed area 0V above slowspeed area	SP O	8
input	24V if footpedal is pressed 0V if footpedal is not pressed	FUS_I	9
input	0V if footpedal is pressed 24V if footpedal is not pressed	FUO_I	10
input	24V highspped allowed (AKAS) 0V slowspeed request (AKAS)	SGA	11
input	OPTIONAL: safetypoint from NC controller	SP_I	12
input	24V if boxbending selected (AKAS3) 0V if flatbending selected (AKAS3)	HUSP	13
	not connected		14

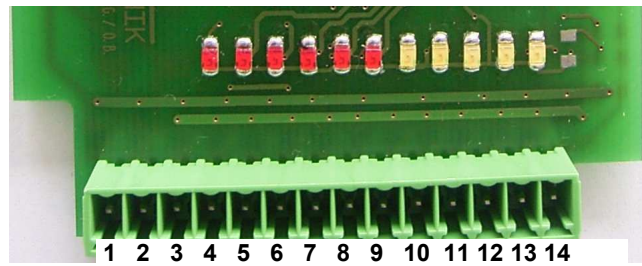

Operation mode for AKAS is : 9, C, 9, C
or if EDM feedback is too slow : 9, D, 9, D

Only AKAS systems with serial number before 57650 must use operation mode D,C,D,C or D,D,D,D because of different software in AKAS receiver

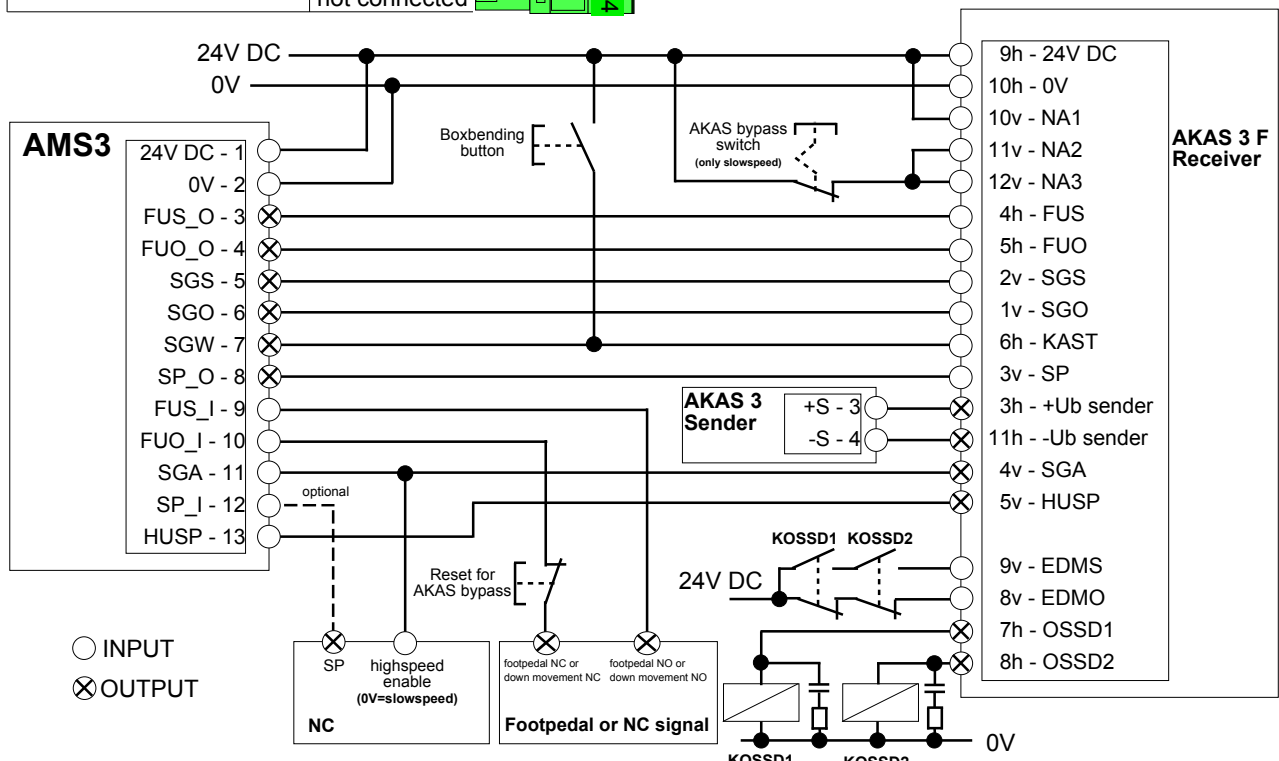

4. Electrical connection

4.3 Connecting AMS3 to AKAS II F



Operation mode for AKAS is : 9, C, 9, C
 or if EDM feedback is too slow : 9, D, 9, D for +100ms time delay

Only AKAS systems with serial number before 57650
 must use operation mode D,C,D,C or D,D,D,D
 because of different software in AKAS receiver

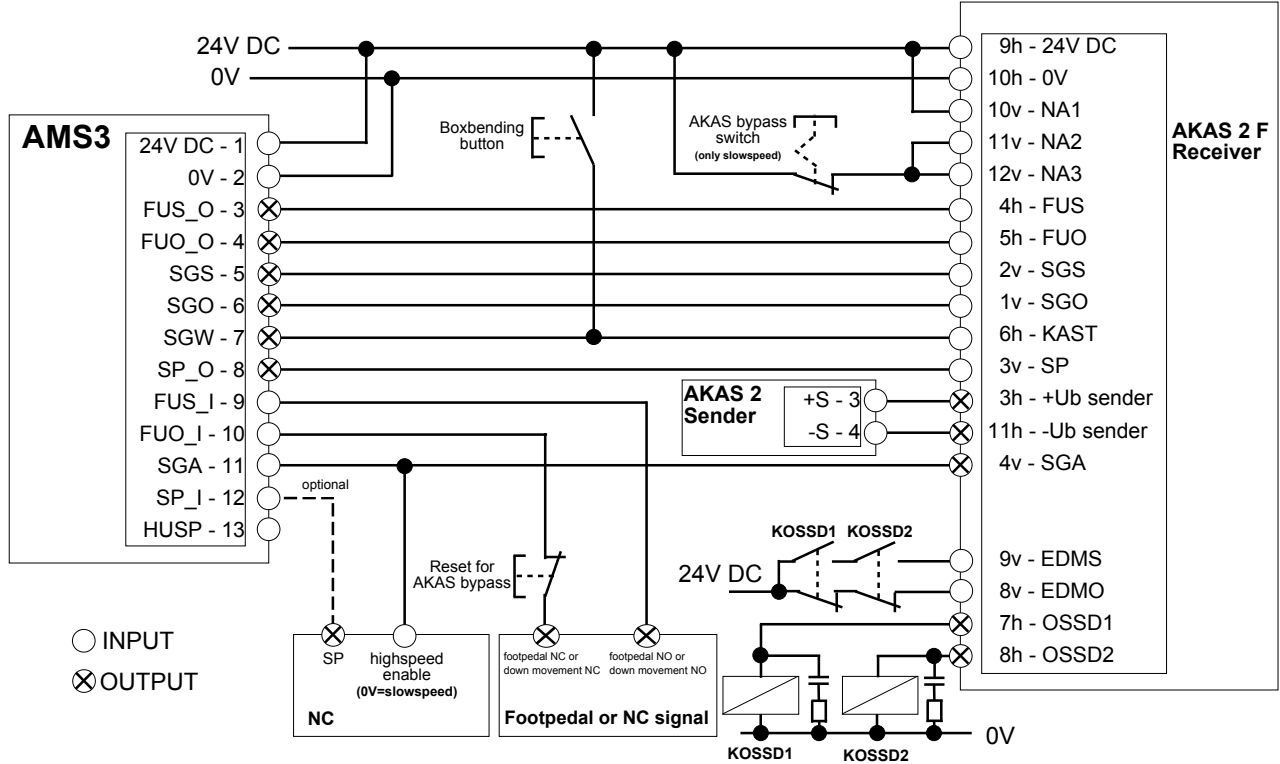

4.4 Connecting AMS3 to AKAS LC F



Operation mode for AKAS is : 9, C, 9, C
 or if EDM feedback is too slow : 9, D, 9, D for +100ms time delay

Only AKAS systems with serial number before 57650
 must use operation mode D,C,D,C or D,D,D,D
 because of different software in AKAS receiver

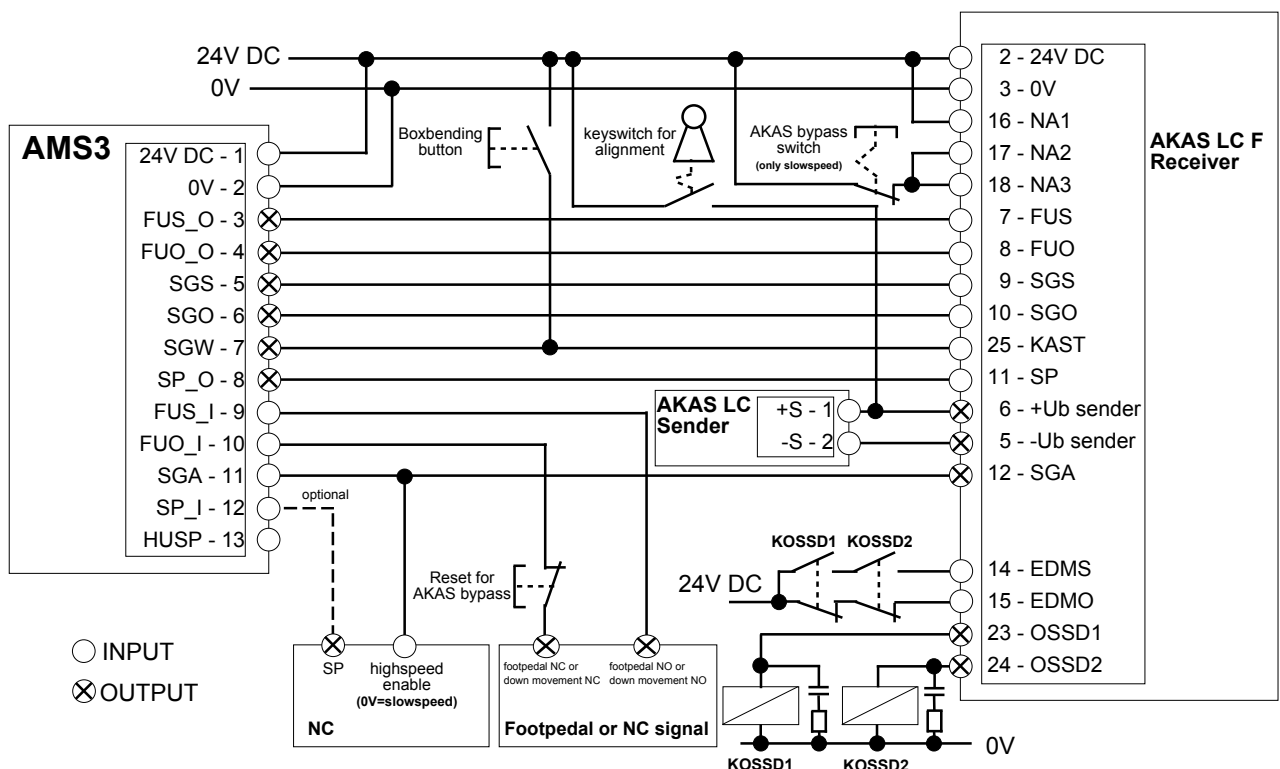

5. Technical data	
Safety category	4
Protection type	AMS3 must be mounted inside a cabinet of protection type IP54
Protection class	III
Ambient operating temperature	-10 to 50 °C
Storage temperature	-25 to 70 °C
Supply voltage	24 V DC, ±20%, (SELV). The external supply voltage must be able to bridge brief power failures for up to 20 ms according to EN 60 204.
Current consumption	Max. 250 mA.
Outputs	FUS_o, FUO_o, SGS, SGO, SGW and SP_o : PNP outputs, max. 0.5 A,
Inputs	FUO_i, FUS_i, SGA, SP_i and HUSP : 0 V / 24V DC +/- 20 %, 10 mA
Connection cable	max. 1.5 mm ²
protection from incorrect connection	Protection against all possibilities of errors is not provided
cable arrangement	Cables to be laid separately from high-voltage cables. The cable laying must be arranged in a way that no mechanical damage is possible.

6. Faults / Possible causes / Remedies		
Fault	Possible causes	Remedies
Overrun test does not show the measurement result.	Footpedal was released after the machine stopped	Keep footpedal activated to see the measurement result (L3/L4 flashing).
After overrun test is finished, SP_OUTPUT is flashing.	After AMS showed the overrun value with L3/L4 footpedal is still pressed.	Release the footpedal. Press footpedal again for down movement.
After overrun test has stopped the machine, SP_OUTPUT is flashing.	Overrun test failed. Machine did not stop within the limit.	Repeat the overrun test. If it fails again you can reduce the machine speed.
AMS LEDs L3 and L4 flashing 12 times after power on	Different operation modes selected on DIP_1 and DIP_2	Select the same operation mode on both dipswitch and restart AMS
AMS LEDs L3 and L4 flashing 1 time after at least two complete strokes	Machine fast down movement Y1 and Y2 is more than 15mm out of sync	Check machine hydraulic. Maybe also one scale sensor out of order.

Service

If you have any questions that cannot be answered by reading this operating manual, please contact us directly.

When calling, please have the following details ready:

- Device designation
- Serial number
- Fault symptoms and description

Fiessler Elektronik
Kastellstraße 9
D-73734 Esslingen

Phone +49-711-919697-0
Fax +49-711-919697-50
E-mail info@fiessler.de

Returning a unit

If a unit proves defective and needs to be returned, the following details will greatly help us in repairing the fault quickly:

- Exact fault description
- Has the machine furnished with the AMS exhibited other faults?
- Have you noticed any other failures in the past?
- In which operating mode was the unit last used?

The more precise the fault description, the more efficiently and reliably we will be able to pinpoint and eliminate the fault.

Download area

The latest operating manuals, device descriptions etc. can be downloaded free-of-charge from our homepage.

<http://www.fiessler.de>

Additional safety products

Apart from the safety controllers described here, Fiessler Elektronik supplies further components for ensuring workplace safety.

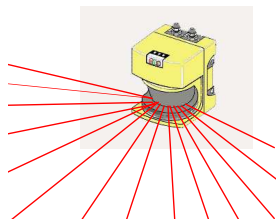
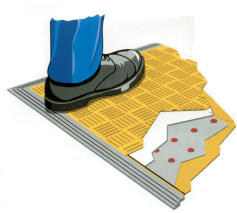

Laser scanners

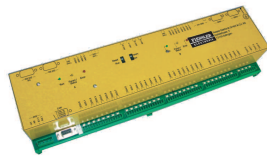

Parametrizable safety controller FPSC

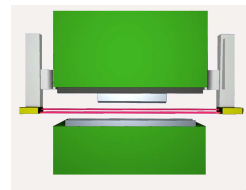

Press brake protection system AKAS



Light curtains for safety, control and measurement

Service

Service seminars and integration support by our service team.

Certification

A quality management system was introduced at an early stage to guarantee the high quality of Fiessler safety equipment. Fiessler Elektronik is certified according to DIN ISO EN 9001. The company's own electromagnetic compatibility laboratory tests products on a regular basis. All safety equipment complies with national and European standards. Development takes place in consultation with the relevant trade associations. Certification is received followed rigorous tests by the Technical Inspection Board.



Recognition

by Baden Württemberg's ministry of economy of outstanding performance by the innovative AKAS safety system.



**Fiessler Elektronik
GmbH & Co. KG**
Kastellstr. 9
D-73734 Esslingen

Phone: +49(0)711 -91 96 97-0
Fax: +49(0)711-91 96 97-50
Email: info@fiessler.de
Internet: www.fiessler.de

Represented in all major countries

